



## Series 9

Intelligent Precision Air Conditioning System

---

*Technical Data - 50Hz*

## **Table of Contents**

<b>Table of Contents .....</b>	<b>2</b>
<b>Air-cooled System .....</b>	<b>3</b>
<b>Water-cooled System .....</b>	<b>5</b>
<b>Glycol-cooled System .....</b>	<b>7</b>
<b>Chilled-Water System.....</b>	<b>9</b>
<b>Air Dual-cooling System.....</b>	<b>11</b>
<b>Water Dual-cooling System.....</b>	<b>14</b>
<b>Glycol Dual-cooling System.....</b>	<b>17</b>
<b>Glycol Free-cooling System .....</b>	<b>20</b>
<b>Electrical Data .....</b>	<b>23</b>
<b>Dimensional Drawings.....</b>	<b>27</b>

## Air-cooled System

Model no.	9AU	/9AD	06	08	12	14	16	18	20	22	26
<b>Cooling Capacity - Rated at standard air volume &amp; 49°C condensing temperature</b>											
<b>24°C(75.2°F)DB, 50%rh</b>											
Total	kW		23.5	31.3	42.1	49.1	61.0	64.7	69.8	81.2	85.5
Sensible	kW		21.8	29.0	37.6	46.0	55.4	60.9	63.7	72.3	82.1
THR	kW		28.3	38.1	50.4	59.5	74.3	78.0	85.4	100.9	104.4
<b>24°C(75.2°F)DB, 45%rh</b>											
Total	kW		22.9	30.6	41.2	48.0	59.8	63.2	68.3	79.5	83.8
Sensible	kW		22.9	30.6	40.9	48.0	59.8	63.2	68.3	78.2	83.8
THR	kW		27.7	36.1	49.6	58.4	73.1	76.5	83.8	98.4	102.7
<b>22°C(71.6°F)DB, 50%rh</b>											
Total	kW		22.0	29.5	40.0	46.4	57.9	60.9	66.0	76.9	81.2
Sensible	kW		20.9	28.7	36.8	44.8	54.0	59.0	61.9	70.7	81.2
THR	kW		26.9	36.3	48.3	56.8	71.2	74.2	81.5	95.8	100.1
<b>22°C(71.6°F)DB, 45%rh</b>											
Total	kW		21.5	28.9	39.3	45.4	56.8	60.0	65.1	75.8	79.9
Sensible	kW		21.5	28.9	39.3	45.4	56.8	60.0	65.1	75.8	79.9
THR	kW		26.4	35.7	47.6	55.7	70.0	73.3	80.6	94.7	98.8
<b>20°C(68.0°F)DB, 50%rh</b>											
Total	kW		20.6	27.9	38.1	43.7	54.9	57.9	63.0	73.4	77.3
Sensible	kW		20.6	27.6	36.3	43.7	53.1	57.7	60.7	69.5	77.3
THR	kW		25.5	34.7	46.4	54.1	68.1	71.1	78.4	92.3	96.3
<b>20°C(68.0°F)DB, 45%rh</b>											
Total	kW		20.1	27.3	38.8	42.5	53.5	57.1	62.1	72.3	76.1
Sensible	kW		20.1	27.3	38.8	42.5	53.5	57.1	62.1	72.3	76.1
THR	kW		25.0	34.1	46.1	52.8	66.7	70.3	77.5	91.2	95.0
<b>Fan Section - Two belts, variable pitch, single shaft centrifugal blower system with pillow block bearings</b>											
Standard Air Volume	m <sup>3</sup> /h		6120	8840	10540	14960	17680	18360	20400	21080	25500
External Static Pressure	Pa		75	75	75	75	75	75	75	75	75
Quantity of Fans			2	2	2	2	2	2	2	2	3
Total Fan Motor Power	kW		0.75	1.49	2.24	2.24	3.73	3.73	5.60	5.60	7.46
<b>Compressor - Refrigerant R22</b>											
Quantity of Compressors			2	2	2	2	2	2	2	2	2
Type			Scroll	Scroll	Scroll	Scroll	Scroll	Scroll	Scroll	Scroll	Scroll
<b>Evaporator Coil - A-Frame- Copper tube / aluminium fin - Stainless steel drain pan</b>											
Face Area	m <sup>2</sup>		1.25	1.25	1.25	2.13	2.13	2.13	2.13	2.13	2.81
Rows Deep			3	3	4	3	3	4	4	4	4
Fins per inch			14	14	14	13	13	13	13	13	13
Face Velocity	m/s		1.36	1.97	2.35	1.95	2.31	2.39	2.66	2.75	2.52
Refrigerant Charge	kg		3.5	3.5	4.6	5.9	5.9	7.9	7.9	7.9	9.1

Model no. 9AU_/9AD_†		06	08	12	14	16	18	20	22	26
<b>Reheat Section</b>										
<i>Electric Reheat<sup>1</sup> - Fully proportional, finned tubular type heater, SCR Controlled</i>										
Capacity	kW	12	12	12	24	24	24	24	24	30
Quantity of Heaters		3	3	3	3	3	3	3	3	3
<i>Hot Gas Reheat - 22°C E.A.T.</i>										
Heating Capacity	kW	8.6	10.1	10.8	17.0	18.2	18.4	19.2	19.4	25.4
<i>Hot Water Reheat - 82.2°C E.W.T., 22°C E.A.T. - 2-way modulating control valve, optional 3-way</i>										
Heating Capacity	kW	12.9	14.7	15.6	23.3	24.6	24.8	25.6	25.8	32.1
Water Flow Rate	l/s	0.32	0.32	0.32	0.32	0.32	0.32	0.32	0.32	0.32
Pressure Drop	kPa	2.0	2.0	2.0	2.9	2.9	2.9	2.9	2.9	3.7
<i>Steam Reheat - 108.3°C saturated steam, 22°C E.A.T. - 2-way modulating control valve</i>										
Heating Capacity	kW	20.6	24.0	25.6	40.4	43.1	43.7	45.4	45.9	60.2
<b>Humidifier Section</b>										
<i>Electrode Boiler Type, Serviceable Bottle<sup>1</sup></i>										
Capacity	kg/h	9	9	9	9	9	9	9	9	9
Humidifier Power	kW	6.8	6.8	6.8	6.8	6.8	6.8	6.8	6.8	6.8
<b>Filter Section - Pleated disposable type</b>										
<i>Upflow Models</i>										
Quantity of Filters		3	3	3	4	4	4	4	4	5
Nominal Size	LxWxD-mm	508 x 635 x 101.6				508 x 635 x 101.6				
<i>Downflow Models</i>										
Quantity of Filters		4	4	4	6	6	6	6	6	8
Nominal Size	LxWxD-mm	406.4 x 635 x 101.6				406.4 x 635 x 101.6				
<b>Piping Connection Size</b>										
Liquid Line	- ODM -mm	12.7	12.7	12.7	15.9	15.9	15.9	15.9	15.9	22.2
Hot Gas Line	- ODM -mm	22.2	22.2	22.2	28.6	28.6	28.6	28.6	28.6	28.6
Hot Water	- ODM -mm	22.2	22.2	22.2	22.2	22.2	22.2	22.2	22.2	22.2
Steam	- MPT -mm	22.2	22.2	22.2	22.2	22.2	22.2	22.2	22.2	22.2
Steam Condensate-	ODM -mm	19.1	19.1	19.1	19.1	19.1	19.1	19.1	19.1	19.1
Humidifier Water	- ODM -mm	6.35	6.35	6.35	6.35	6.35	6.35	6.35	6.35	6.35
Condensate Drain	- ODM -mm	19.1	19.1	19.1	19.1	19.1	19.1	19.1	19.1	19.1
<b>Physical Details - For units with standard options only; consult factory for special options and configuration</b>										
Dimensions	mm	1854(W) x 864(D) x 1880(H)				2515(W) x 864(D) x 1880(H)				**
Approx. Weight	kg	600	615	635	800	810	840	845	845	1012
<b>Air Cooled Condenser - Factory matched</b>										
Model*		KCV05-1	KCV05-1	KCV08-1	KCV10-1	KCV10-1	KCV10-1	KD224-2	KD227-2	KD329-2
No. of Condenser		2	2	2	2	2	2	1	1	1
<b>Alternative Air Cooled Condenser</b>										
Model*		KD109-2	KD111-2	KD113-2	KD217-2	KD219-2	KD222-2	-	-	-
No. of Condenser		1	1	1	1	1	1	-	-	-

\* Based on maximum ambient of 38°C, \*\* Dimensions for 26 Ton Unit 3175(W) x 864(D) x 1880(H)

<sup>1</sup> Standard options (Consult factory for other selections)

## Water-cooled System

Model no. 9WU_/9WD_†		06	08	12	14	16	18	20	22	26
<b>Cooling Capacity - Rated at standard air volume, 46°C condensing temperature</b>										
<b>24°C(75.2°F)DB, 50%rh</b>										
Total	kW	23.2	30.6	39.9	47.6	59.6	63.3	71.2	84.5	88.8
Sensible	kW	21.6	28.7	36.6	45.3	54.8	60.3	64.3	73.7	83.6
THR	kW	28.0	37.4	48.2	58.1	72.9	76.6	86.7	103.4	107.8
<b>24°C(75.2°F)DB, 45%rh</b>										
Total	kW	22.6	30.0	38.9	46.6	58.4	61.7	69.5	82.5	86.8
Sensible	kW	22.6	30.0	38.9	46.6	58.4	61.7	69.0	79.5	86.8
THR	kW	27.3	36.8	47.2	57.1	71.6	75.1	85.0	101.5	105.8
<b>22°C(71.6°F)DB, 50%rh</b>										
Total	kW	21.9	28.9	37.4	45.1	56.5	59.4	67.0	79.6	83.8
Sensible	kW	20.8	28.4	35.7	44.2	53.3	58.3	62.4	72.0	82.7
THR	kW	26.7	35.7	45.8	55.5	69.7	72.7	82.5	98.5	102.8
<b>22°C(71.6°F)DB, 45%rh</b>										
Total	kW	21.4	28.4	36.7	44.2	55.3	58.6	66.0	78.3	82.3
Sensible	kW	21.4	28.4	36.7	44.2	55.3	58.6	66.0	78.3	82.3
THR	kW	26.3	35.2	45.0	54.5	68.6	71.8	81.5	97.3	101.2
<b>20°C(68.0°F)DB, 50%rh</b>										
Total	kW	20.7	27.4	35.3	42.7	53.5	56.4	63.7	75.6	79.4
Sensible	kW	20.7	27.4	35.0	42.7	52.4	56.4	61.0	70.5	79.4
THR	kW	25.6	34.2	43.6	53.0	66.7	69.7	79.1	94.5	98.3
<b>20°C(68.0°F)DB, 45%rh</b>										
Total	kW	20.3	26.8	35.0	41.5	52.1	55.6	62.7	74.3	77.9
Sensible	kW	20.3	26.8	35.0	41.5	52.1	55.6	62.7	74.3	77.9
THR	kW	25.1	33.6	43.3	51.9	65.3	68.9	78.2	93.2	96.9
<b>Fan Section - Two belts, variable pitch, single shaft centrifugal blower system with pillow block bearings</b>										
Standard Air Volume	m <sup>3</sup> /h	6120	8840	10540	14960	17680	18360	20400	21080	25500
External Static Pressure	Pa	75	75	75	75	75	75	75	75	75
Quantity of Fans		2	2	2	2	2	2	2	2	3
Total Fan Motor Power	kW	0.75	1.49	2.24	2.24	3.73	3.73	5.60	5.60	7.46
<b>Compressor - Refrigerant R22</b>										
Quantity of Compressors		2	2	2	2	2	2	2	2	2
Type		Scroll	Scroll	Scroll	Scroll	Scroll	Scroll	Scroll	Scroll	Scroll
<b>Evaporator Coil - A-Frame - Copper tube / aluminium fin - Stainless steel drain pan</b>										
Face Area	m <sup>2</sup>	1.25	1.25	1.25	2.13	2.13	2.13	2.13	2.13	2.81
Rows Deep		3	3	4	3	3	4	4	4	4
Fins per inch		14	14	14	13	13	13	13	13	13
Face Velocity	m/s	1.36	1.97	2.35	1.95	2.31	2.39	2.66	2.75	2.52

Model no.	9WU__/9WD__ <sup>†</sup>	06	08	12	14	16	18	20	22	26
<b>Reheat Section</b>										
<i>Electric Reheat</i> <sup>1</sup> - Fully proportional, finned tubular type heater, SCR Controlled										
Capacity	kW	12	12	12	24	24	24	24	24	30
Quantity of Heaters		3	3	3	3	3	3	3	3	3
<i>Hot Gas Reheat</i> - 22°C E.A.T.										
Heating Capacity	kW	8.6	10.1	10.8	17.0	18.2	18.4	19.2	19.4	25.4
<i>Hot Water Reheat</i> - 82.2°C E.W.T., 22°C E.A.T. - 2-way modulating control valve, optional 3-way										
Heating Capacity	kW	12.9	14.7	15.6	23.3	24.6	24.8	25.6	25.8	32.1
Water Flow Rate	l/s	0.32	0.32	0.32	0.32	0.32	0.32	0.32	0.32	0.32
Pressure Drop	kPa	2.0	2.0	2.0	2.9	2.9	2.9	2.9	2.9	3.7
<i>Steam Reheat</i> - 108.3°C saturated steam, 22°C E.A.T. - 2-way modulating control valve										
Heating Capacity	kW	20.6	24.0	25.6	40.4	43.1	43.7	45.4	45.9	60.2
<b>Humidifier Section</b>										
<i>Electrode Boiler Type, Serviceable Bottle</i> <sup>1</sup>										
Capacity	kg/h	9	9	9	9	9	9	9	9	9
Humidifier Power	kW	6.8	6.8	6.8	6.8	6.8	6.8	6.8	6.8	6.8
<b>Filter Section</b> - Pleated disposable type										
<i>Upflow Models</i>										
Quantity of Filters		3	3	3	4	4	4	4	4	5
Nominal Size	LxWxD-mm	508 x 635 x 101.6				508 x 635 x 101.6				
<i>Downflow Models</i>										
Quantity of Filters		4	4	4	6	6	6	6	6	8
Nominal Size	LxWxD-mm	406.4 x 635 x 101.6				406.4 x 635 x 101.6				
<b>Condensing Water Requirement</b>										
<b>35°C EWT</b>										
Flow Rate	l/s	0.92	1.40	2.13	1.72	2.39	2.58	3.15	4.18	4.67
Unit Pressure Drop	kPa	24.9	55.5	63.1	75.1	69.9	86.1	81.0	89.9	74.3
<b>32.2°C EWT</b>										
Flow Rate	l/s	0.69	1.02	1.49	1.30	1.75	1.88	2.25	2.95	3.10
Unit Pressure Drop	kPa	15.5	29.7	32.2	47.9	35.7	48.6	42.0	56.9	31.6
<b>Water Regulating Valve</b> - 2-way, head pressure controlled										
Size	mm	19.1	19.1	25.4	19.1	25.4	25.4	31.8	38.1	38.1
<b>Piping Connection Size</b>										
Liquid Line	- ODM - mm	12.7	12.7	12.7	15.9	15.9	15.9	15.9	15.9	22.2
Hot Gas Line	- ODM - mm	22.2	22.2	22.2	28.6	28.6	28.6	28.6	28.6	28.6
Condensing Water	- ODM - mm	28.6	28.6	34.9	34.9	34.9	41.3	41.3	41.3	41.3
Hot Water	- ODM - mm	22.2	22.2	22.2	22.2	22.2	22.2	22.2	22.2	22.2
Steam	- MPT - mm	22.2	22.2	22.2	22.2	22.2	22.2	22.2	22.2	22.2
Steam Condensate	- ODM - mm	19.1	19.1	19.1	19.1	19.1	19.1	19.1	19.1	19.1
Humidifier Water	- ODM - mm	6.35	6.35	6.35	6.35	6.35	6.35	6.35	6.35	6.35
Condensate Drain	- ODM - mm	19.1	19.1	19.1	19.1	19.1	19.1	19.1	19.1	19.1
<b>Physical Details*</b> - For units with standard options only; consult factory for special options and configuration										
Dimensions	mm	1854(W) x 864(D) x 1880(H)				2515(W) x 864(D) x 1880(H)				**
Approx. Weight	kg	735	748	771	948	957	989	998	998	1103

\*\* Dimensions for 26 Ton Unit 3172(W) x 864(D) x 1880(H)

<sup>1</sup> Standard Options (Consult factory for other selections)

## Glycol-cooled System

Model no. 9GU_/9GD_†		06	08	12	14	16	18	20	22	26
<b>Cooling Capacity - Rated at standard air volume</b>										
<b>24°C(75.2°F)DB, 50%rh</b>										
Total	kW	23.2	30.6	39.9	47.6	59.6	63.3	71.2	84.5	88.8
Sensible	kW	21.6	28.7	36.6	45.3	54.8	60.3	64.3	73.7	83.6
THR	kW	28.0	37.4	48.2	58.1	72.9	76.6	86.7	103.4	107.8
<b>24°C(75.2°F)DB, 45%rh</b>										
Total	kW	22.6	30.0	38.9	46.6	58.4	61.7	69.5	82.5	86.8
Sensible	kW	22.6	30.0	38.9	46.6	58.4	61.7	69.0	79.5	86.8
THR	kW	27.3	36.8	47.2	57.1	71.6	75.1	85.0	101.5	105.8
<b>22°C(71.6°F)DB, 50%rh</b>										
Total	kW	21.9	28.9	37.4	45.1	56.5	59.4	67.0	79.6	83.8
Sensible	kW	20.8	28.4	35.7	44.2	53.3	58.3	62.4	72.0	82.7
THR	kW	26.7	35.7	45.8	55.5	69.7	72.7	82.5	98.5	102.8
<b>22°C(71.6°F)DB, 45%rh</b>										
Total	kW	21.4	28.4	36.7	44.2	55.3	58.6	66.0	78.3	82.3
Sensible	kW	21.4	28.4	36.7	44.2	55.3	58.6	66.0	78.3	82.3
THR	kW	26.3	35.2	45.0	54.5	68.6	71.8	81.5	97.3	101.2
<b>20°C(68.0°F)DB, 50%rh</b>										
Total	kW	20.7	27.4	35.3	42.7	53.5	56.4	63.7	75.6	79.4
Sensible	kW	20.7	27.4	35.0	42.7	52.4	56.4	61.0	70.5	79.4
THR	kW	25.6	34.2	43.6	53.0	66.7	69.7	79.1	94.5	98.3
<b>20°C(68.0°F)DB, 45%rh</b>										
Total	kW	20.3	26.8	35.0	41.5	52.1	55.6	62.7	74.3	77.9
Sensible	kW	20.3	26.8	35.0	41.5	52.1	55.6	62.7	74.3	77.9
THR	kW	25.1	33.6	43.3	51.9	65.3	68.9	78.2	93.2	96.9
<b>Fan Section - Two belts, variable pitch, single shaft centrifugal blower system with pillow block bearings</b>										
Standard Air Volume	m <sup>3</sup> /h	6120	8840	10540	14960	17680	18360	20400	21080	25500
External Static Pressure	Pa	75	75	75	75	75	75	75	75	75
Quantity of Fans		2	2	2	2	2	2	2	2	3
Total Fan Motor Power	kW	0.75	1.49	2.24	2.24	3.73	3.73	5.60	5.60	7.46
<b>Compressor - Refrigerant R22</b>										
Quantity of Compressors		2	2	2	2	2	2	2	2	2
Type		Scroll	Scroll	Scroll	Scroll	Scroll	Scroll	Scroll	Scroll	Scroll
<b>Evaporator Coil - A-Frame - Copper tube / aluminium fin - Stainless steel drain pan</b>										
Face Area	m <sup>2</sup>	1.25	1.25	1.25	2.13	2.13	2.13	2.13	2.13	2.81
Rows Deep		3	3	4	3	3	4	4	4	4
Fins per inch		14	14	14	13	13	13	13	13	13
Face Velocity	m/s	1.36	1.97	2.35	1.95	2.31	2.39	2.66	2.75	2.52

Model no. 9GU__/9GD__ <sup>†</sup>	06	08	12	14	16	18	20	22	26
<b>Reheat Section</b>									
<i>Electric Reheat<sup>1</sup> - Fully proportional, finned tubular type heater, SCR Controlled</i>									
Capacity kW	12	12	12	24	24	24	24	24	30
Quantity of Heaters	3	3	3	3	3	3	3	3	3
<i>Hot Gas Reheat - 22°C E.A.T.</i>									
Heating Capacity kW	8.6	10.1	10.8	17.0	18.2	18.4	19.2	19.4	25.4
<i>Hot Water Reheat - 82.2°C E.W.T., 22°C E.A.T. - 2-way modulating control valve, optional 3-way</i>									
Heating Capacity kW	12.9	14.7	15.6	23.3	24.6	24.8	25.6	25.8	32.1
Water Flow Rate l/s	0.32	0.32	0.32	0.32	0.32	0.32	0.32	0.32	0.32
Pressure Drop kPa	2.0	2.0	2.0	2.9	2.9	2.9	2.9	2.9	3.7
<i>Steam Reheat - 108.3°C saturated steam, 22°C E.A.T. - 2-way modulating control valve</i>									
Heating Capacity kW	20.6	24.0	25.6	40.4	43.1	43.7	45.4	45.9	60.2
<b>Humidifier Section</b>									
<i>Electrode Boiler Type, Serviceable Bottle<sup>1</sup></i>									
Capacity kg/h	9	9	9	9	9	9	9	9	9
Humidifier Power kW	6.8	6.8	6.8	6.8	6.8	6.8	6.8	6.8	6.8
<b>Filter Section - Pleated disposable type</b>									
<i>Upflow Models</i>									
Quantity of Filters	3	3	3	4	4	4	4	4	5
Nominal Size LxWxD-mm	508 x 635 x 101.6				508 x 635 x 101.6				
<i>Downflow Models</i>									
Quantity of Filters	4	4	4	6	6	6	6	6	8
Nominal Size LxWxD-mm	406.4 x 635 x 101.6				406.4 x 635 x 101.6				
<b>Glycol Solution Requirement - 40% ethylene glycol</b>									
<b>40. 5°C EWT</b>									
Flow Rate l/s	1.44	2.26	3.28	2.51	2.64	2.83	3.40	4.47	5.16
Unit Pressure Drop kPa	51.9	75.5	82.8	78.6	85.7	94.2	84.3	115.6	42.3
<b>35°C EWT</b>									
Flow Rate l/s	0.86	1.28	1.87	1.49	1.60	1.65	2.23	3.48	2.57
Unit Pressure Drop kPa	21.7	26.1	34.2	29.8	34.2	33.9	31.9	40.5	13.6
<b>Glycol Solution Regulating Valve - 2-way, head pressure controlled</b>									
Size mm	19.1	25.4	31.8	25.4	25.4	25.4	31.8	38.1	50.8
<b>Piping Connection Size</b>									
Liquid Line - ODM -mm	12.7	12.7	12.7	15.9	15.9	15.9	15.9	15.9	22.2
Hot Gas Line - ODM -mm	22.2	22.2	22.2	28.6	28.6	28.6	28.6	28.6	28.6
Condensing Water - ODM -mm	28.6	28.6	34.9	34.9	34.9	41.3	41.3	41.3	41.3
Hot Water - ODM -mm	22.2	22.2	22.2	22.2	22.2	22.2	22.2	22.2	22.2
Steam - MPT -mm	22.2	22.2	22.2	22.2	22.2	22.2	22.2	22.2	22.2
Steam Condensate - ODM -mm	19.1	19.1	19.1	19.1	19.1	19.1	19.1	19.1	19.1
Humidifier Water - ODM -mm	6.35	6.35	6.35	6.35	6.35	6.35	6.35	6.35	6.35
Condensate Drain - ODM -mm	19.1	19.1	19.1	19.1	19.1	19.1	19.1	19.1	19.1
<b>Physical Details* - For units with standard options only; consult factory for special options and configuration</b>									
Dimensions mm	1854(W) x 864(D) x 1880(H)					2515(W) x 864(D) x 1880(H)			**
Approx. Weight kg	735	748	771	948	957	989	998	998	1103

\*\* Dimensions for 26 Ton Unit 3172(W) x 863(D) x 1880(H)

<sup>1</sup> Standard Options (Consult factory for other selections)



## Chilled-Water System

Model no. 9CU__ / 9CD__		14	16	18	20	22	25	26	30
<b>Cooling Capacity</b> - Rated at standard air volume, 7.2°C entering water & 5.6°C temperature rise									
<b>26°C(78.8°F)DB, 50%rh</b>									
Total	kW	76.4	88.3	100.5	119.9	130.4	143.9	153.1	188.5
Sensible	kW	57.0	67.3	78.2	89.1	98.4	104.7	114.9	134.7
Flow Rate	l/s	3.29	3.80	4.13	5.15	5.67	6.18	6.62	8.11
Unit Pressure Drop	kPa	57	71	80	131	152	65	140	107
<b>26°C(78.8°F)DB, 45%rh</b>									
Total	kW	69.4	80.5	91.8	109.3	119.2	130.9	139.0	171.7
Sensible	kW	58.3	68.9	80.1	91.2	100.8	106.6	116.3	136.9
Flow Rate	l/s	2.98	3.46	3.95	4.70	5.72	5.63	5.99	7.38
Unit Pressure Drop	kPa	49	62	69	113	132	58	122	94
<b>24°C(75.2°F)DB, 50%rh</b>									
Total	kW	61.2	70.8	80.7	96.5	104.8	118.8	122.6	156.4
Sensible	kW	50.3	59.3	69.9	79.6	87.9	94.8	101.6	122.0
Flow Rate	l/s	2.62	3.04	3.47	4.15	5.04	5.17	5.30	6.72
Unit Pressure Drop	kPa	40	50	56	91	105	53	107	83
<b>24°C(75.2°F)DB, 45%rh</b>									
Total	kW	56.1	65.3	71.3	88.8	95.6	109.7	112.5	143.5
Sensible	kW	52.3	61.7	71.3	82.8	90.2	97.6	104.2	124.8
Flow Rate	l/s	2.41	2.81	3.07	3.82	3.94	4.72	4.86	6.17
Unit Pressure Drop	kPa	35	44	46	79	84	49	96	74
<b>22°C(71.6°F)DB, 50%rh</b>									
Total	kW	47.8	52.6	60.8	75.7	81.9	97.6	96.2	128.4
Sensible	kW	45.0	52.6	60.8	71.2	77.3	85.5	90.9	109.8
Flow Rate	l/s	2.06	2.26	2.61	3.26	3.43	4.20	4.16	5.52
Unit Pressure Drop	kPa	27	32	35	61	66	43	84	64
<b>22°C(71.6°F)DB, 45%rh</b>									
Total	kW	44.8	52.6	60.8	71.0	78.0	91.7	90.3	119.6
Sensible	kW	44.8	52.6	60.8	71.0	78.0	89.4	90.3	114.1
Flow Rate	l/s	1.92	2.26	2.61	3.05	3.36	3.94	3.91	5.14
Unit Pressure Drop	kPa	25	32	35	55	64	40	76	59
<b>Fan Section</b> - Two belts, variable pitch, single shaft centrifugal blower system with pillow block bearings									
Standard Air Volume	m <sup>3</sup> /h	11900	14620	17680	18700	21080	20390	23800	25500
External Static Pressure	Pa	75	75	75	75	75	75	75	75
Quantity of Fans		2	2	2	2	2	2	3	3
Total Fan Motor Power	kW	2.24	3.76	3.73	5.60	5.60	7.46	7.46	7.46

Model no.	9CU__ / 9CD__	14	16	18	20	22	25	26	30	
<b>Chilled-water Coil - A-Frame - Copper tube / aluminium fin - Stainless steel drain pan</b>										
Face Area	m <sup>2</sup>	2.13	2.13	2.13	2.13	2.13	2.13	2.81	2.81	
Rows Deep		4	4	4	5	5	6	5	6	
Fins per inch		13	13	13	13	13	13	13	13	
Face Velocity	m/s	1.55	1.91	2.31	2.44	2.75	2.66	2.35	2.52	
<b>Reheat Section</b>										
<i>Electric Reheat<sup>1</sup> - Fully Proportional, finned tubular type heater, SCR Controlled</i>										
Capacity	kW	24	24	24	24	24	30	30	30	
Quantity of Heaters		3	3	3	3	3	3	3	3	
<i>Hot Water Reheat - 82.2°C E.W.T., 22°C E.A.T. - 2-way modulating control valve, optional 3-way</i>										
Heating Capacity	kW	23.3	24.6	24.8	25.6	25.8	25.6	31.5	32.1	
Water Flow Rate	l/s	0.32	0.32	0.32	0.32	0.32	0.32	0.32	0.32	
Pressure Drop	kPa	2.9	2.9	2.9	2.9	2.9	2.9	3.7	3.7	
<i>Steam Reheat - 108.3°C saturated steam, 22°C E.A.T. - 2-way modulating control valve</i>										
Heating Capacity	kW	40.4	43.1	43.7	45.4	45.9	45.4	58.7	60.2	
<b>Humidifier Section</b>										
<i>Electrode Boiler Type, Serviceable Bottle<sup>1</sup></i>										
Capacity	kg/h	9	9	9	9	9	9	9	9	
Humidifier Power	kW	6.8	6.8	6.8	6.8	6.8	6.8	6.8	6.8	
<b>Filter Section - Pleated disposable type</b>										
<i>Upflow Models</i>										
Quantity of Filters		4	4	4	4	4	4	5	5	
Nominal Size	LxWxD-mm	508 x 635 x 101.6								
<i>Downflow Models</i>										
Quantity of Filters		6	6	6	6	6	6	8	8	
Nominal Size	LxWxD-mm	406.4 x 635 x 101.6								
<b>Chilled-water Valve - 3-Way modulating</b>										
Valve Size	mm	38.1	38.1	50.8	50.8	50.8	50.8	50.8	50.8	
<b>Piping Connection Size</b>										
Chilled-water	- ODM -mm	41.3	41.3	54.0	54.0	54.0	54.0	54.0	54.0	
Hot Water	- ODM -mm	22.2	22.2	22.2	22.2	22.2	22.2	22.2	22.2	
Steam	- MPT -mm	22.2	22.2	22.2	22.2	22.2	22.2	22.2	22.2	
Steam Condensate	- ODM -mm	19.1	19.1	19.1	19.1	19.1	19.1	19.1	19.1	
Humidifier Water	- ODM -mm	6.35	6.35	6.35	6.35	6.35	6.35	6.35	6.35	
Condensate Drain	- ODM -mm	19.1	19.1	19.1	19.1	19.1	19.1	19.1	19.1	
<b>Physical Details - For units with standard options only; consult factory for special options and configuration</b>										
Dimensions	mm	2515(W) x 864(D) x 1880(H)						3715(W) x 864(D) x 880(H)		
Weight	kg	665	665	715	720	720	731	855	876	

<sup>1</sup>Standard options

## Air Dual-cooling System

Model no.	9DU__/9DD__	06	08	12	14	16	18	20	22	26
<b>Cooling Capacity - Rated at standard air volume &amp; 49°C condensing temperature</b>										
<b>24°C(75.2°F)DB, 50%rh</b>										
Total	kW	23.5	31.3	40.3	49.1	61.0	61.3	65.9	77.4	81.3
Sensible	kW	21.8	29.0	35.8	46.0	55.4	56.7	59.2	67.8	76.6
THR	kW	28.3	38.1	48.6	59.5	74.3	74.6	81.4	96.3	100.2
<b>24°C(75.2°F)DB, 45%rh</b>										
Total	kW	22.9	30.6	39.6	48.0	59.8	60.1	64.7	76.0	80.1
Sensible	kW	22.9	30.6	38.9	48.0	59.8	60.1	63.9	73.2	80.1
THR	kW	27.7	37.4	48.0	58.4	73.1	73.4	80.2	94.9	99.1
<b>22°C(71.6°F)DB, 50%rh</b>										
Total	kW	22.0	29.5	38.5	46.4	57.9	58.2	62.9	73.8	78.0
Sensible	kW	20.9	28.7	35.5	44.8	54.0	55.1	57.7	66.2	73.3
THR	kW	26.9	36.3	46.8	56.8	71.2	71.5	78.3	92.8	97.0
<b>22°C(71.6°F)DB, 45%rh</b>										
Total	kW	21.5	28.9	38.0	45.4	56.8	57.1	61.7	72.4	76.3
Sensible	kW	21.5	28.9	38.0	45.4	56.8	57.1	61.7	71.3	76.3
THR	kW	26.4	35.7	46.2	55.7	70.0	70.3	77.1	91.4	95.2
<b>20°C(68.0°F)DB, 50%rh</b>										
Total	kW	20.6	27.9	36.9	43.7	54.9	55.2	59.9	70.3	74.2
Sensible	kW	20.6	27.6	34.5	43.7	53.1	54.2	56.9	65.3	72.6
THR	kW	25.5	34.7	45.2	54.1	68.1	68.4	75.3	89.3	93.1
<b>20°C(68.0°F)DB, 45%rh</b>										
Total	kW	20.1	27.3	36.3	42.5	53.5	53.8	58.5	68.8	72.5
Sensible	kW	20.1	27.3	36.3	42.5	53.5	53.8	58.5	68.8	72.5
THR	kW	25.0	34.1	44.6	52.8	66.7	67.0	73.8	87.8	91.4
<b>Cooling Capacity - Chilled-water - Rated at standard air volume, 7.2°C entering water &amp; 5.6°C water temperature rise</b>										
<b>24°C(75.2°F)DB, 50%rh</b>										
Total	kW	26.7	34.9	39.7	58.6	65.2	66.8	71.3	72.8	77.3
Sensible	kW	22.1	29.2	33.7	53.2	59.7	61.7	67.5	68.4	77.3
Flow/Pressure Drop	l/s/kPa	1.15/18	1.50/29	1.7/37	2.52/16	2.80/20	2.87/21	3.07/23	3.13/24	3.32/27
<b>24°C(75.2°F)DB, 45%rh</b>										
Total	kW	22.6	30.0	34.2	53.3	60.2	61.8	66.5	68.0	77.3
Sensible	kW	22.6	30.0	34.2	53.3	60.2	61.8	66.5	68.0	77.3
Flow/Pressure Drop	l/s/kPa	0.97/14	1.29/22	1.47/28	2.27/14	2.59/17	2.66/18	2.86/20	2.93/21	3.32/27
<b>22°C(71.6°F)DB, 50%rh</b>										
Total	kW	20.6	25.4	29.0	45.3	50.9	52.3	56.2	57.4	65.2
Sensible	kW	19.5	25.4	29.0	45.3	50.9	52.3	56.2	57.4	65.2
Flow/Pressure Drop	l/s/kPa	0.89/12	1.09/17	1.24/21	1.95/10	2.19/13	2.25/13	2.42/15	2.42/16	2.80/20
<b>22°C(71.6°F)DB, 45%rh</b>										
Total	kW	19.2	25.4	29.0	45.3	50.9	52.3	56.2	57.4	65.2
Sensible	kW	19.2	25.4	29.0	45.3	50.9	52.3	56.2	57.4	65.2
Flow/Pressure Drop	l/s/kPa	0.83/10	1.09/17	1.24/21	1.95/10	2.19/13	2.25/13	2.42/15	2.42/16	2.80/20
<b>20°C(68.0°F)DB, 50%rh</b>										
Total	kW	15.8	20.8	23.7	37.0	41.6	42.7	45.8	46.8	52.9
Sensible	kW	15.8	20.8	23.7	37.0	41.6	42.7	45.8	46.8	52.9
Flow/Pressure Drop	l/s/kPa	0.67/7	0.90/12	1.02/15	1.59/7	1.79/9	1.84/9	1.97/11	2.01/11	2.30/14
<b>20°C(68.0°F)DB, 45%rh</b>										
Total	kW	15.8	20.8	23.7	37.0	41.6	42.7	45.8	46.8	52.9
Sensible	kW	15.8	20.8	23.7	37.0	41.6	42.7	45.8	46.8	52.9
Flow/Pressure Drop	l/s/kPa	0.67/7	0.90/12	1.02/15	1.59/7	1.79/9	1.84/9	1.97/11	2.01/11	2.30/14

Model no. 9DU_/9DD_	06	08	12	14	16	18	20	22	26
<b>Fan Section - Two belts, variable pitch, single shaft centrifugal blower system with pillow block bearings</b>									
Standard Air Volume m <sup>3</sup> /h	6120	8840	10540	14960	17680	18360	20400	21080	25500
External Static Pressure Pa	75	75	75	75	75	75	75	75	75
Quantity of Fans	2	2	2	2	2	2	2	2	3
Total Fan Motor Power kW	0.75	1.49	3.73	3.73	3.73	5.60	5.60	5.60	7.46
<b>Compressor - Refrigerant R22</b>									
Quantity of Compressors	2	2	2	2	2	2	2	2	2
Type	Scroll	Scroll	Scroll	Scroll	Scroll	Scroll	Scroll	Scroll	Scroll
<b>Evaporator Coil - A-Frame- Copper tube / aluminium fin - Stainless steel drain pan</b>									
Face Area m <sup>2</sup>	1.25	1.25	1.25	2.13	2.13	2.13	2.13	2.13	2.81
Rows Deep (DX/Chilled Water)	3/3	3/3	3/3	3/3	3/3	3/3	3/3	3/3	3/3
Fins per inch	14	14	14	13	13	13	13	13	13
Face Velocity m/s	1.36	1.96	2.34	1.95	2.31	2.39	2.66	2.75	2.52
<b>Reheat Section</b>									
<i>Electric Reheat<sup>1</sup> - Fully proportional, finned tubular type heater, SCR Controlled</i>									
Capacity kW	12	12	12	24	24	24	24	24	30
Quantity of Heaters	3	3	3	3	3	3	3	3	3
<i>Hot Gas Reheat - 22°C E.A.T.</i>									
Heating Capacity kW	8.6	10.1	10.8	17.0	18.2	18.4	19.2	19.4	25.4
<i>Hot Water Reheat - 82.2°C E.W.T., 22°C E.A.T. - 2-way modulating control valve, optional 3-way</i>									
Heating Capacity kW	12.9	14.7	15.6	23.3	24.6	24.8	25.6	25.8	32.1
Water Flow Rate l/s	0.32	0.32	0.32	0.32	0.32	0.32	0.32	0.32	0.32
Pressure Drop kPa	2.0	2.0	2.0	2.9	2.9	2.9	2.9	2.9	3.7
<i>Steam Reheat - 108.3°C saturated steam, 22°C E.A.T. - 2-way modulating control valve</i>									
Heating Capacity kW	20.6	24.0	25.6	40.4	43.1	43.7	45.4	45.9	60.2
<b>Humidifier Section</b>									
<i>Electrode Boiler Type, Serviceable Bottle<sup>1</sup></i>									
Capacity kg/h	9	9	9	9	9	9	9	9	9
Humidifier Power kW	6.8	6.8	6.8	6.8	6.8	6.8	6.8	6.8	6.8
<b>Filter Section - Pleated disposable type</b>									
<i>Upflow Models</i>									
Quantity of Filters	3	3	3	4	4	4	4	4	5
Nominal Size LxWxD-mm	508 x 635 x 101.6				508 x 635 x 101.6				
<i>Downflow Models</i>									
Quantity of Filters	4	4	4	6	6	6	6	6	8
Nominal Size LxWxD-mm	406.4 x 635 x 101.6				406.4 x 635 x 101.6				
<b>Chilled-water Valve - 3-Way modulating</b>									
Valve Size mm	25.4	25.4	38.1	38.1	38.1	50.8	50.8	50.8	50.8

Model no. 9DU_/9DD_		06	08	12	14	16	18	20	22	26	
<b>Piping Connection Size</b>											
Liquid Line	- ODM -mm	12.7	12.7	12.7	15.9	15.9	15.9	15.9	15.9	15.9	
Hot Gas Line	- ODM -mm	22.2	22.2	22.2	28.6	28.6	28.6	28.6	28.6	28.6	
Hot Water	- ODM -mm	22.2	22.2	22.2	22.2	22.2	22.2	22.2	22.2	22.2	
Steam	- MPT -mm	22.2	22.2	22.2	22.2	22.2	22.2	22.2	22.2	22.2	
Steam Condensate-	ODM -mm	19.1	19.1	19.1	19.1	19.1	19.1	19.1	19.1	19.1	
Humidifier Water	- ODM -mm	6.35	6.35	6.35	6.35	6.35	6.35	6.35	6.35	6.35	
Condensate Drain	- ODM -mm	19.1	19.1	19.1	19.1	19.1	19.1	19.1	19.1	19.1	
<b>Physical Details*</b> - For units with standard options only; consult factory for special options and configuration											
Dimensions	mm	2085(W) x 864(D) x 1880(H)					2745(W) x 864(D) x 1880(H)				**
Approx. Weight	kg	667	681	726	840	862	908	930	930	1125	
<b>Air cooled Condenser – Factory Matched</b>											
Model*		KCV05-1	KCV05-1	KCV08-1	KCV10-1	KCV10-1	KCV10-1	KD224-2	KD227-2	KD329-2	
No. of Condenser		2	2	2	2	2	2	1	1	1	
<b>Alternative Air cooled Condenser</b>											
Model*		KD109-2	KD111-2	KD113-2	KD217-2	KD219-2	KD222-2	-	-	-	
No. of Condenser		1	1	1	1	1	1	-	-	-	

\* Based on maximum ambient of 38°C, \*\* Dimensions for 26 Ton Unit 3172(W) x 863(D) x 1880(H)

<sup>1</sup> Standard Options (Consult factory for other selections)

# Water Dual-cooling System

Model no.	9HU__/9HD__	06	08	12	14	16	18	20	22	26
<b>Cooling Capacity – Direct Expansion - Rated at standard air volume &amp; 46°C condensing temperature</b>										
<b>24°C(75.2°F)DB, 50%rh</b>										
Total	kW	23.2	30.6	37.8	47.6	59.6	59.9	67.5	80.2	84.0
Sensible	kW	21.6	28.7	34.7	45.3	54.8	56.0	60.0	69.0	77.7
THR	kW	28.0	37.4	46.1	58.1	72.9	73.2	83.0	99.1	102.9
<b>24°C(75.2°F)DB, 45%rh</b>										
Total	kW	22.6	30.0	37.0	46.6	58.4	58.7	66.2	78.6	82.6
Sensible	kW	22.6	30.0	37.0	46.6	58.4	58.7	64.6	74.3	82.6
THR	kW	27.5	36.8	45.3	57.1	71.6	72.0	81.7	97.5	101.5
<b>22°C(71.6°F)DB, 50%rh</b>										
Total	kW	21.9	28.9	35.7	45.1	56.5	56.8	64.1	76.1	80.2
Sensible	kW	20.8	28.4	34.2	44.2	53.3	54.5	58.3	67.2	74.3
THR	kW	26.7	35.7	44.0	55.5	69.7	70.0	79.6	95.1	99.2
<b>22°C(71.6°F)DB, 45%rh</b>										
Total	kW	21.4	28.4	35.1	44.2	55.3	55.6	62.8	74.5	78.2
Sensible	kW	21.4	28.4	35.1	44.2	55.3	55.6	62.8	72.2	78.2
THR	kW	26.3	35.2	43.4	54.5	68.6	68.9	78.3	93.5	97.1
<b>20°C(68.0°F)DB, 50%rh</b>										
Total	kW	20.7	27.4	33.9	42.7	53.5	53.8	60.8	72.1	75.8
Sensible	kW	20.6	27.4	33.0	42.7	52.4	53.5	57.3	66.1	73.3
THR	kW	25.6	34.2	42.2	53.0	66.7	67.0	76.2	91.0	94.7
<b>20°C(68.0°F)DB, 45%rh</b>										
Total	kW	20.3	26.8	33.2	41.5	52.1	52.4	59.3	70.4	73.9
Sensible	kW	20.3	26.8	33.2	41.5	52.1	52.4	59.3	70.4	73.9
THR	kW	25.1	33.6	41.5	51.9	65.3	65.6	74.6	89.3	92.8
<b>Cooling Capacity - Chilled-water - Rated at standard air volume, 7.2°C entering water &amp; 5.6°C water temperature rise</b>										
<b>24°C(75.2°F)DB, 50%rh</b>										
Total	kW	26.7	34.9	39.7	58.6	65.2	66.8	71.3	72.8	77.3
Sensible	kW	22.1	29.2	33.7	53.2	59.7	61.7	67.5	68.4	77.3
Flow/Pressure Drop	l/s/kPa	1.15/18	1.50/29	1.7/37	2.52/16	2.80/20	2.87/21	3.07/23	3.13/24	3.32/27
<b>24°C(75.2°F)DB, 45%rh</b>										
Total	kW	22.6	30.0	34.2	53.3	60.2	61.8	66.5	68.0	77.3
Sensible	kW	22.6	30.0	34.2	53.3	60.2	61.8	66.5	68.0	77.3
Flow/Pressure Drop	l/s/kPa	0.97/14	1.29/22	1.47/28	2.27/14	2.59/17	2.66/18	2.86/20	2.93/21	3.32/27
<b>22°C(71.6°F)DB, 50%rh</b>										
Total	kW	20.6	25.4	29.0	45.3	50.9	52.3	56.2	57.4	65.2
Sensible	kW	19.5	25.4	29.0	45.3	50.9	52.3	56.2	57.4	65.2
Flow/Pressure Drop	l/s/kPa	0.89/12	1.09/17	1.24/21	1.95/10	2.19/13	2.25/13	2.42/15	2.42/16	2.80/20
<b>22°C(71.6°F)DB, 45%rh</b>										
Total	kW	19.2	25.4	29.0	45.3	50.9	52.3	56.2	57.4	65.2
Sensible	kW	19.2	25.4	29.0	45.3	50.9	52.3	56.2	57.4	65.2
Flow/Pressure Drop	l/s/kPa	0.83/10	1.09/17	1.24/21	1.95/10	2.19/13	2.25/13	2.42/15	2.42/16	2.80/20
<b>20°C(68.0°F)DB, 50%rh</b>										
Total	kW	15.8	20.8	23.7	37.0	41.6	42.7	45.8	46.8	52.9
Sensible	kW	15.8	20.8	23.7	37.0	41.6	42.7	45.8	46.8	52.9
Flow/Pressure Drop	l/s/kPa	0.67/7	0.90/12	1.02/15	1.59/7	1.79/9	1.84/9	1.97/11	2.01/11	2.30/14
<b>20°C(68.0°F)DB, 45%rh</b>										
Total	kW	15.8	20.8	23.7	37.0	41.6	42.7	45.8	46.8	52.9
Sensible	kW	15.8	20.8	23.7	37.0	41.6	42.7	45.8	46.8	52.9
Flow/Pressure Drop	l/s/kPa	0.67/7	0.90/12	1.02/15	1.59/7	1.79/9	1.84/9	1.97/11	2.01/11	2.30/14

Model no. 9HU__/9HD__ <sup>†</sup>	06	08	12	14	16	18	20	22	26
<b>Fan Section - Two belts, variable pitch, single shaft centrifugal blower system with pillow block bearings</b>									
Standard Air Volume m <sup>3</sup> /h	6120	8840	10540	14960	17680	18360	20400	21080	25500
External Static Pressure Pa	75	75	75	75	75	75	75	75	75
Quantity of Fans	2	2	2	2	2	2	2	2	3
Total Fan Motor Power kW	0.75	1.49	3.73	3.73	3.73	5.60	5.60	5.60	7.46
<b>Compressor - Refrigerant R22</b>									
Quantity of Compressors	2	2	2	2	2	2	2	2	2
Type	Scroll	Scroll	Scroll	Scroll	Scroll	Scroll	Scroll	Scroll	Scroll
<b>Evaporator Coil - A-Frame- Copper tube / aluminium fin - Stainless steel drain pan</b>									
Face Area m <sup>2</sup>	1.25	1.25	1.25	2.13	2.13	2.13	2.13	2.13	2.81
Rows Deep (DX/Chilled Water)	3/3	3/3	3/3	3/3	3/3	3/3	3/3	3/3	3/3
Fins per inch	14	14	14	13	13	13	13	13	13
Face Velocity m/s	1.36	1.97	2.35	1.95	2.31	2.39	2.66	2.75	2.52
<b>Reheat Section</b>									
<i>Electric Reheat<sup>1</sup> - Fully proportional, finned tubular type heater, SCR Controlled</i>									
Capacity kW	12	12	12	24	24	24	24	24	30
Quantity of Heaters	3	3	3	3	3	3	3	3	3
<i>Hot Gas Reheat - 22°C E.A.T.</i>									
Heating Capacity kW	8.6	10.1	10.8	17.0	18.2	18.4	19.2	19.4	25.4
<i>Hot Water Reheat - 82.2°C E.W.T., 22°C E.A.T. - 2-way modulating control valve, optional 3-way</i>									
Heating Capacity kW	12.9	14.7	15.6	23.3	24.6	24.8	25.6	25.8	32.1
Water Flow Rate l/s	0.32	0.32	0.32	0.32	0.32	0.32	0.32	0.32	0.32
Pressure Drop kPa	2.0	2.0	2.0	2.9	2.9	2.9	2.9	2.9	3.7
<i>Steam Reheat - 108.3°C saturated steam, 22°C E.A.T. - 2-way modulating control valve</i>									
Heating Capacity kW	20.6	24.0	25.6	40.4	43.1	43.7	45.4	45.9	60.2
<b>Humidifier Section</b>									
<i>Electrode Boiler Type, Serviceable Bottle<sup>1</sup></i>									
Capacity kg/h	9	9	9	9	9	9	9	9	9
Humidifier Power kW	6.8	6.8	6.8	6.8	6.8	6.8	6.8	6.8	6.8
<b>Filter Section - Pleated disposable type</b>									
<i>Upflow Models</i>									
Quantity of Filters	3	3	3	4	4	4	4	4	5
Nominal Size LxWxD-mm	508 x 635 x 101.6				508 x 635 x 101.6				
<i>Downflow Models</i>									
Quantity of Filters	4	4	4	6	6	6	6	6	8
Nominal Size LxWxD-mm	406.4 x 635 x 101.6				406.4 x 635 x 101.6				

Model no. 9HU__/9HD__		06	08	12	14	16	18	20	22	26
<b>Condensing Water Requirement</b>										
<b>35°C EWT</b>										
Flow Rate	l/s	0.92	1.40	1.97	1.72	2.39	2.40	2.93	3.98	4.45
Unit Pressure Drop	kPa	24.2	56.9	109.7	78.5	69.9	70.3	104.4	104.1	70.4
<b>32.2°C EWT</b>										
Flow Rate	l/s	0.69	1.02	1.39	1.30	1.75	1.76	2.11	2.76	2.96
Unit Pressure Drop	kPa	15.5	28.7	56.5	46.5	37.0	37.2	56.6	49.5	30.4
<b>Water Regulating Valve - 2-way, head pressure controlled</b>										
Size	mm	19.1	19.1	19.1	19.1	25.4	25.4	25.4	38.1	38.1
<b>Chilled-water Valve - 3-Way modulating</b>										
Valve Size	mm	25.4	25.4	38.1	38.1	38.1	50.8	50.8	50.8	50.8
<b>Piping Connection Size</b>										
Liquid Line	- ODM -mm	12.7	12.7	12.7	15.9	15.9	15.9	15.9	15.9	22.2
Hot Gas Line	- ODM -mm	22.2	22.2	22.2	28.6	28.6	28.6	28.6	28.6	28.6
Condensing Water	- ODM -mm	28.6	28.6	34.9	34.9	34.9	41.3	41.3	41.3	41.3
Chilled Water	-ODM -mm	28.6	28.6	41.3	41.3	41.3	54.0	54.0	54.0	54.0
Hot Water	- ODM -mm	22.2	22.2	22.2	22.2	22.2	22.2	22.2	22.2	22.2
Steam	- MPT -mm	22.2	22.2	22.2	22.2	22.2	22.2	22.2	22.2	22.2
Steam Condensate	- ODM -mm	19.1	19.1	19.1	19.1	19.1	19.1	19.1	19.1	19.1
Humidifier Water	- ODM -mm	6.35	6.35	6.35	6.35	6.35	6.35	6.35	6.35	6.35
Condensate Drain	- ODM -mm	19.1	19.1	19.1	19.1	19.1	19.1	19.1	19.1	19.1
<b>Physical Details - For units with standard options only; consult factory for special options and configuration</b>										
Dimensions	mm	2085(W) x 864(D) x 1880(H)				2745(W) x 864(D) x 1880(H)				**
Approx. Weight	kg	840	890	944	1021	1048	1094	1125	1125	1216

\*\* Dimensions for 26 Ton Unit 3175(W) x 864(D) x 1880(H)

<sup>1</sup> Standard Options (Consult factory for other selections)



# Glycol Dual-cooling System

Model no.	9EU_/9ED_†	06	08	12	14	16	18	20	22	26
<b>Cooling Capacity – Direct Expansion - Rated at standard air volume &amp; 46°C condensing temperature</b>										
<b>24°C(75.2°F)DB, 50%rh</b>										
Total	kW	23.2	30.6	37.8	47.6	59.6	59.9	67.5	80.2	84.0
Sensible	kW	21.6	28.7	34.7	45.3	54.8	56.0	60.0	69.0	77.7
THR	kW	28.0	37.4	46.1	58.1	72.9	73.2	83.0	99.1	102.9
<b>24°C(75.2°F)DB, 45%rh</b>										
Total	kW	22.6	30.0	37.0	46.6	58.4	58.7	66.2	78.6	82.6
Sensible	kW	22.6	30.0	37.0	46.6	58.4	58.7	64.6	74.3	82.6
THR	kW	27.5	36.8	45.3	57.1	71.6	72.0	81.7	97.5	101.5
<b>22°C(71.6°F)DB, 50%rh</b>										
Total	kW	21.9	28.9	35.7	45.1	56.5	56.8	64.1	76.1	80.2
Sensible	kW	20.8	28.4	34.2	44.2	53.3	54.5	58.3	67.2	74.3
THR	kW	26.7	35.7	44.0	55.5	69.7	70.0	79.6	95.1	99.2
<b>22°C(71.6°F)DB, 45%rh</b>										
Total	kW	21.4	28.4	35.1	44.2	55.3	55.6	62.8	74.5	78.2
Sensible	kW	21.4	28.4	35.1	44.2	55.3	55.6	62.8	72.2	78.2
THR	kW	26.3	35.2	43.4	54.5	68.6	68.9	78.3	93.5	97.1
<b>20°C(68.0°F)DB, 50%rh</b>										
Total	kW	20.7	27.4	33.9	42.7	53.5	53.8	60.8	72.1	75.8
Sensible	kW	20.6	27.4	33.0	42.7	52.4	53.5	57.3	66.1	73.3
THR	kW	25.6	34.2	42.2	53.0	66.7	67.0	76.2	91.0	94.7
<b>20°C(68.0°F)DB, 45%rh</b>										
Total	kW	20.3	26.8	33.2	41.5	52.1	52.4	59.3	70.4	73.9
Sensible	kW	20.3	26.8	33.2	41.5	52.1	52.4	59.3	70.4	73.9
THR	kW	25.1	33.6	41.5	51.9	65.3	65.6	74.6	89.3	92.8
<b>Cooling Capacity - Chilled-water - Rated at standard air volume, 7.2°C entering water &amp; 5.6°C water temperature rise</b>										
<b>24°C(75.2°F)DB, 50%rh</b>										
Total	kW	26.7	34.9	39.7	58.6	65.2	66.8	71.3	72.8	77.3
Sensible	kW	22.1	29.2	33.7	53.2	59.7	61.7	67.5	68.4	77.3
Flow/Pressure Drop	l/s/kPa	1.15/18	1.50/29	1.7/37	2.52/16	2.80/20	2.87/21	3.07/23	3.13/24	3.32/27
<b>24°C(75.2°F)DB, 45%rh</b>										
Total	kW	22.6	30.0	34.2	53.3	60.2	61.8	66.5	68.0	77.3
Sensible	kW	22.6	30.0	34.2	53.3	60.2	61.8	66.5	68.0	77.3
Flow/Pressure Drop	l/s/kPa	0.97/14	1.29/22	1.47/28	2.27/14	2.59/17	2.66/18	2.86/20	2.93/21	3.32/27
<b>22°C(71.6°F)DB, 50%rh</b>										
Total	kW	20.6	25.4	29.0	45.3	50.9	52.3	56.2	57.4	65.2
Sensible	kW	19.5	25.4	29.0	45.3	50.9	52.3	56.2	57.4	65.2
Flow/Pressure Drop	l/s/kPa	0.89/12	1.09/17	1.24/21	1.95/10	2.19/13	2.25/13	2.42/15	2.42/16	2.80/20
<b>22°C(71.6°F)DB, 45%rh</b>										
Total	kW	19.2	25.4	29.0	45.3	50.9	52.3	56.2	57.4	65.2
Sensible	kW	19.2	25.4	29.0	45.3	50.9	52.3	56.2	57.4	65.2
Flow/Pressure Drop	l/s/kPa	0.83/10	1.09/17	1.24/21	1.95/10	2.19/13	2.25/13	2.42/15	2.42/16	2.80/20
<b>20°C(68.0°F)DB, 50%rh</b>										
Total	kW	15.8	20.8	23.7	37.0	41.6	42.7	45.8	46.8	52.9
Sensible	kW	15.8	20.8	23.7	37.0	41.6	42.7	45.8	46.8	52.9
Flow/Pressure Drop	l/s/kPa	0.67/7	0.90/12	1.02/15	1.59/7	1.79/9	1.84/9	1.97/11	2.01/11	2.30/14
<b>20°C(68.0°F)DB, 45%rh</b>										
Total	kW	15.8	20.8	23.7	37.0	41.6	42.7	45.8	46.8	52.9
Sensible	kW	15.8	20.8	23.7	37.0	41.6	42.7	45.8	46.8	52.9
Flow/Pressure Drop	l/s/kPa	0.67/7	0.90/12	1.02/15	1.59/7	1.79/9	1.84/9	1.97/11	2.01/11	2.30/14

Model no. 9EU__/9ED__†	06	08	12	14	16	18	20	22	26
<b>Fan Section - Two belts, variable pitch, single shaft centrifugal blower system with pillow block bearings</b>									
Standard Air Volume m <sup>3</sup> /h	6120	8840	10540	14960	17680	18360	20400	21080	25500
External Static Pressure Pa	75	75	75	75	75	75	75	75	75
Quantity of Fans	2	2	2	2	2	2	2	2	3
Total Fan Motor Power kW	0.75	1.49	3.73	3.73	3.73	5.60	5.60	5.60	7.46
<b>Compressor - Refrigerant R22</b>									
Quantity of Compressors	2	2	2	2	2	2	2	2	2
Type	Scroll	Scroll	Scroll	Scroll	Scroll	Scroll	Scroll	Scroll	Scroll
<b>Evaporator Coil - A-Frame- Copper tube / aluminium fin - Stainless steel drain pan</b>									
Face Area m <sup>2</sup>	1.25	1.25	1.25	2.13	2.13	2.13	2.13	2.13	2.81
Rows Deep (DX/Chilled Water)	3/3	3/3	3/3	3/3	3/3	3/3	3/3	3/3	3/3
Fins per inch	14	14	14	13	13	13	13	13	13
Face Velocity m/s	1.36	1.97	2.34	1.95	2.31	2.39	2.66	2.75	2.52
<b>Reheat Section</b>									
<i>Electric Reheat<sup>1</sup> - Fully proportional, finned tubular type heater, SCR Controlled</i>									
Capacity kW	12	12	12	24	24	24	24	24	30
Quantity of Heaters	3	3	3	3	3	3	3	3	3
<i>Hot Gas Reheat - 22°C E.A.T.</i>									
Heating Capacity kW	8.6	10.1	10.8	17.0	18.2	18.4	19.2	19.4	25.4
<i>Hot Water Reheat - 82.2°C E.W.T., 22°C E.A.T. - 2-way modulating control valve, optional 3-way</i>									
Heating Capacity kW	12.9	14.7	15.6	23.3	24.6	24.8	25.6	25.8	32.1
Water Flow Rate l/s	0.32	0.32	0.32	0.32	0.32	0.32	0.32	0.32	0.32
Pressure Drop kPa	2.0	2.0	2.0	2.9	2.9	2.9	2.9	2.9	3.7
<i>Steam Reheat - 108.3°C saturated steam, 22°C E.A.T. - 2-way modulating control valve</i>									
Heating Capacity kW	20.6	24.0	25.6	40.4	43.1	43.7	45.4	45.9	60.2
<b>Humidifier Section</b>									
<i>Electrode Boiler Type, Serviceable Bottle<sup>1</sup></i>									
Capacity kg/h	9	9	9	9	9	9	9	9	9
Humidifier Power kW	6.8	6.8	6.8	6.8	6.8	6.8	6.8	6.8	6.8
<b>Filter Section - Pleated disposable type</b>									
<i>Upflow Models</i>									
Quantity of Filters	3	3	3	4	4	4	4	4	5
Nominal Size LxWxD-mm	508 x 635 x 101.6				508 x 635 x 101.6				
<i>Downflow Models</i>									
Quantity of Filters	4	4	4	6	6	6	6	6	8
Nominal Size LxWxD-mm	406.4 x 635 x 101.6				406.4 x 635 x 101.6				

Model no. 9EU__/9ED__ <sup>†</sup>		06	08	12	14	16	18	20	22	26	
<b><i>Glycol Solution Requirement - 40% ethylene glycol</i></b>											
<b>40.5°C EWT</b>											
Flow Rate	l/s	1.44	2.26	3.25	2.51	2.64	2.66	3.18	4.18	4.92	
Unit Pressure Drop	kPa	57.5	75.5	105.4	81.4	83.7	84.4	77.0	102.3	86.1	
<b>35°C EWT</b>											
Flow Rate	l/s	0.86	1.28	1.74	1.49	1.60	1.61	1.89	2.39	2.46	
Unit Pressure Drop	kPa	22.1	26.1	31.6	29.8	30.8	30.8	27.9	34.6	22.1	
<b><i>Glycol Solution Regulating Valve - 2-way, head pressure controlled</i></b>											
Size	mm	19.1	25.4	31.8	25.4	25.4	25.4	31.8	38.1	38.1	
<b><i>Chilled-water Valve - 3-Way modulating</i></b>											
Valve Size	mm	25.4	25.4	38.1	38.1	38.1	50.8	50.8	50.8	50.8	
<b><i>Piping Connection Size</i></b>											
Liquid Line	- ODM -mm	12.7	12.7	12.7	15.9	15.9	15.9	15.9	15.9	22.2	
Hot Gas Line	- ODM -mm	22.2	22.2	22.2	28.6	28.6	28.6	28.6	28.6	28.6	
Glycol Solution	- ODM -mm	28.6	28.6	34.9	34.9	34.9	41.3	41.3	41.3	41.3	
Chilled Water	-ODM -mm	28.6	28.6	41.3	41.3	41.3	54.0	54.0	54.0	54.0	
Hot Water	- ODM -mm	22.2	22.2	22.2	22.2	22.2	22.2	22.2	22.2	22.2	
Steam	- MPT -mm	22.2	22.2	22.2	22.2	22.2	22.2	22.2	22.2	22.2	
Steam Condensate	- ODM -mm	19.1	19.1	19.1	19.1	19.1	19.1	19.1	19.1	19.1	
Humidifier Water	- ODM -mm	6.35	6.35	6.35	6.35	6.35	6.35	6.35	6.35	6.35	
Condensate Drain	- ODM -mm	19.1	19.1	19.1	19.1	19.1	19.1	19.1	19.1	19.1	
<b><i>Physical Details - For units with standard options only; consult factory for special options and configuration</i></b>											
Dimensions	mm	2085(W) x 863(D) x 1880(H)					2745(W) x 864(D) x 1880(H)				**
Approx. Weight	kg	840	890	944	1021	1048	1094	1125	1125	1216	

\*\* Dimensions for 26 Ton Unit 3175(W) x 864(D) x 1880(H)

<sup>1</sup> Standard Options (Consult factory for other selections)

# Glycol Free-cooling System

Model no. 9FU_/9FD_†		06	08	12	14	16	18	20	22	26
<b>Cooling Capacity – Direct Expansion - Rated at standard air volume &amp; 46°C condensing temperature</b>										
<b>24°C(75.2°F)DB, 50%rh</b>										
Total	kW	23.2	30.6	37.8	47.6	59.6	59.9	67.5	80.2	84.0
Sensible	kW	21.6	28.7	34.7	45.3	54.8	56.0	60.0	69.0	77.7
THR	kW	28.0	37.4	46.1	58.1	72.9	73.2	83.0	99.1	102.9
<b>24°C(75.2°F)DB, 45%rh</b>										
Total	kW	22.6	30.0	37.0	46.6	58.4	58.7	66.2	78.6	82.6
Sensible	kW	22.6	30.0	37.0	46.6	58.4	58.7	64.6	74.3	82.6
THR	kW	27.5	36.8	45.3	57.1	71.6	72.0	81.7	97.5	101.5
<b>22°C(71.6°F)DB, 50%rh</b>										
Total	kW	21.9	28.9	35.7	45.1	56.5	56.8	64.1	76.1	80.2
Sensible	kW	20.8	28.4	34.2	44.2	53.3	54.5	58.3	67.2	74.3
THR	kW	26.7	35.7	44.0	55.5	69.7	70.0	79.6	95.1	99.2
<b>22°C(71.6°F)DB, 45%rh</b>										
Total	kW	21.4	28.4	35.1	44.2	55.3	55.6	62.8	74.5	78.2
Sensible	kW	21.4	28.4	35.1	44.2	55.3	55.6	62.8	72.2	78.2
THR	kW	26.3	35.2	43.4	54.5	68.6	68.9	78.3	93.5	97.1
<b>20°C(68.0°F)DB, 50%rh</b>										
Total	kW	20.7	27.4	33.9	42.7	53.5	53.8	60.8	72.1	75.8
Sensible	kW	20.6	27.4	33.0	42.7	52.4	53.5	57.3	66.1	73.3
THR	kW	25.6	34.2	42.2	53.0	66.7	67.0	76.2	91.0	94.7
<b>20°C(68.0°F)DB, 45%rh</b>										
Total	kW	20.3	26.8	33.2	41.5	52.1	52.4	59.3	70.4	73.9
Sensible	kW	20.3	26.8	33.2	41.5	52.1	52.4	59.3	70.4	73.9
THR	kW	25.1	33.6	41.5	51.9	65.3	65.6	74.6	89.3	92.8
<b>Cooling Capacity – 100% Free-cooling - Rated at standard air volume, 7.2°C entering glycol</b>										
<b>24°C(75.2°F)DB, 50%rh</b>										
Total	kW	25.6	33.7	38.7	51.4	58.6	60.0	70.2	76.3	93.8
Sensible	kW	21.2	28.3	32.6	51.4	58.6	60.0	66.5	70.4	86.3
<b>24°C(75.2°F)DB, 45%rh</b>										
Total	kW	23.7	30.2	35.9	51.4	58.6	60.0	67.7	72.2	88.9
Sensible	kW	22.1	30.2	33.9	51.4	58.6	60.0	67.7	72.2	88.9
<b>22°C(71.6°F)DB, 50%rh</b>										
Total	kW	21.1	27.9	31.9	45.3	51.6	52.9	59.7	63.6	78.3
Sensible	kW	19.5	26.0	29.9	45.3	51.6	52.9	59.7	63.6	78.3
<b>22°C(71.6°F)DB, 45%rh</b>										
Total	kW	20.0	26.6	30.5	45.3	51.6	52.9	59.7	63.6	78.3
Sensible	kW	20.0	26.6	30.5	45.3	51.6	52.9	59.7	63.6	78.3
<b>20°C(68.0°F)DB, 50%rh</b>										
Total	kW	17.3	23.0	26.4	39.2	44.6	45.7	51.6	55.0	67.7
Sensible	kW	17.3	23.0	26.4	39.2	44.6	45.7	51.6	55.0	67.7
<b>20°C(68.0°F)DB, 45%rh</b>										
Total	kW	17.3	23.0	26.4	39.2	44.6	45.7	51.6	55.0	67.7
Sensible	kW	17.3	23.0	26.4	39.2	44.6	45.7	51.6	55.0	67.7

Model no. 9FU_/9FD_†	06	08	12	14	16	18	20	22	26
<b>Fan Section - Two belts, variable pitch, single shaft centrifugal blower system with pillow block bearings</b>									
Standard Air Volume m <sup>3</sup> /h	6120	8840	10540	14960	17680	18360	20400	21080	25500
External Static Pressure Pa	75	75	75	75	75	75	75	75	75
Quantity of Fans	2	2	2	2	2	2	2	2	3
Total Fan Motor Power kW	0.75	1.49	3.73	3.73	3.73	5.60	5.60	5.60	7.46
<b>Compressor - Refrigerant R22</b>									
Quantity of Compressors	2	2	2	2	2	2	2	2	2
Type	Scroll	Scroll	Scroll	Scroll	Scroll	Scroll	Scroll	Scroll	Scroll
<b>Evaporator Coil - A-Frame- Copper tube / aluminium fin - Stainless steel drain pan</b>									
Face Area m <sup>2</sup>	1.25	1.25	1.25	2.13	2.13	2.13	2.13	2.13	2.81
Rows Deep (DX/Chilled Water)	3/3	3/3	3/3	3/3	3/3	3/3	3/3	3/3	3/3
Fins per inch	14	14	14	13	13	13	13	13	13
Face Velocity m/s	1.36	1.97	2.35	1.95	2.31	2.39	2.66	2.75	2.52
<b>Reheat Section</b>									
<i>Electric Reheat<sup>1</sup> - Fully proportional, finned tubular type heater, SCR Controlled</i>									
Capacity kW	12	12	12	24	24	24	24	24	30
Quantity of Heaters	3	3	3	3	3	3	3	3	3
<i>Hot Gas Reheat - 22°C E.A.T.</i>									
Heating Capacity kW	8.6	10.1	10.8	17.0	18.2	18.4	19.2	19.4	25.4
<i>Hot Water Reheat - 82.2°C E.W.T., 22°C E.A.T. - 2-way modulating control valve, optional 3-way</i>									
Heating Capacity kW	12.9	14.7	15.6	23.3	24.6	24.8	25.6	25.8	32.1
Water Flow Rate l/s	0.32	0.32	0.32	0.32	0.32	0.32	0.32	0.32	0.32
Pressure Drop kPa	2.0	2.0	2.0	2.9	2.9	2.9	2.9	2.9	3.7
<i>Steam Reheat - 108.3°C saturated steam, 22°C E.A.T. - 2-way modulating control valve</i>									
Heating Capacity kW	20.6	24.0	25.6	40.4	43.1	43.7	45.4	45.9	60.2
<b>Humidifier Section</b>									
<i>Electrode Boiler Type, Serviceable Bottle<sup>1</sup></i>									
Capacity kg/h	9	9	9	9	9	9	9	9	9
Humidifier Power kW	6.8	6.8	6.8	6.8	6.8	6.8	6.8	6.8	6.8
<b>Filter Section - Pleated disposable type</b>									
<i>Upflow Models</i>									
Quantity of Filters	3	3	3	4	4	4	4	4	5
Nominal Size LxWxD-mm	508 x 635 x 101.6				508 x 635 x 101.6				
<i>Downflow Models</i>									
Quantity of Filters	4	4	4	6	6	6	6	6	8
Nominal Size LxWxD-mm	406.4 x 635 x 101.6				406.4 x 635 x 101.6				

Model no. 9FU__/9FD__ <sup>†</sup>		06	08	12	14	16	18	20	22	26	
<b><i>Glycol Solution Regulating Valve - 3-way modulating</i></b>											
Valve Size	mm	25.4	25.4	25.4	25.4	31.8	31.8	31.8	38.1	38.1	
Quantity of Valves		2	2	2	2	2	2	2	2	2	
<b><i>Glycol Solution Requirement - 40% ethylene glycol at 7.2°C entering temperature, 0°C ambient temperature</i></b>											
Flow Rate	l/s	0.84	1.14	1.66	2.04	2.66	2.92	2.68	3.92	5.48	
Unit Pressure Drop	kPa	98	158	190	115	115	117	180	260	290	
<b><i>Piping Connection Size</i></b>											
Liquid Line	- ODM -mm	12.7	12.7	12.7	15.9	15.9	15.9	15.9	15.9	22.2	
Hot Gas Line	- ODM -mm	22.2	22.2	22.2	28.6	28.6	28.6	28.6	28.6	28.6	
Glycol Solution	- ODM -mm	28.6	28.6	34.9	34.9	34.9	41.3	41.3	41.3	41.3	
Hot Water	- ODM -mm	22.2	22.2	22.2	22.2	22.2	22.2	22.2	22.2	22.2	
Steam	- MPT -mm	22.2	22.2	22.2	22.2	22.2	22.2	22.2	22.2	22.2	
Steam Condensate-	ODM -mm	19.1	19.1	19.1	19.1	19.1	19.1	19.1	19.1	19.1	
Humidifier Water	- ODM -mm	6.35	6.35	6.35	6.35	6.35	6.35	6.35	6.35	6.35	
Condensate Drain	- ODM -mm	19.1	19.1	19.1	19.1	19.1	19.1	19.1	19.1	19.1	
<b><i>Physical Details - For units with standard options only; consult factory for special options and configuration</i></b>											
Dimensions	mm	2085(W) x 863(D) x 1880(H)					2745(W) x 864(D) x 1880(H)				**
Approx. Weight	kg	840	890	944	1021	1048	1094	1125	1125	1216	

\*\* Dimensions for 26 Ton Unit 3175(W) x 864(D) x 1880(H)

<sup>†</sup> Standard Options (Consult factory for other selections)

# Electrical Data (380V/3PH/50Hz)

## Air / Water / Glycol / Cooled Systems\*†

Model	9_06			9_08			9_12		
	FLA	MCA	MFS	FLA	MCA	MFS	FLA	MCA	MFS
Reheat/Humidifier Option									
Electric (12kW)/Boiler	33.6	39.1	45	38.9	44.8	50	43.7	50.1	60
Electric (12kW)/None	33.6	39.1	45	38.9	44.8	50	43.7	50.1	60
Electric (6kW)/Boiler	25.8	29.3	35	31.0	35.2	40	35.8	40.2	45
Electric (6kW)/None	24.6	27.8	30	29.8	33.5	35	34.6	38.7	45
None, Non-electric/Boiler	25.8	29.3	35	31.0	35.2	40	35.8	40.2	45
None, Non-electric/None	15.5	16.4	20	20.7	22.1	30	25.5	27.3	35

Model	9_14			9_16			9_18			9_20			9_22		
	FLA	MCA	MFS	FLA	MCA	MFS	FLA	MCA	MFS	FLA	MCA	MFS	FLA	MCA	MFS
Reheat/Humidifier Option															
Electric (24kW)/Boiler	70.3	82.3	90	79.3	92.1	100	79.3	92.1	100	86.7	100.0	110	96.9	111.5	120
Electric (24kW)/None	70.3	82.3	90	79.3	92.1	100	79.3	92.1	100	86.7	100.0	110	96.9	111.5	120
Electric (12kW)/Boiler	52.1	59.5	70	61.0	69.2	80	61.0	69.2	80	68.6	77.3	90	78.8	88.8	100
Electric (12kW)/None	52.1	59.5	70	61.0	69.2	80	61.0	69.2	80	68.6	77.3	90	78.8	88.8	100
None, Non-electric/Boiler	44.2	49.7	60	53.2	59.4	70	53.2	59.4	70	60.6	67.3	80	70.8	78.8	100
None, Non-electric/None	33.9	36.8	50	42.9	46.5	60	42.9	46.5	60	50.3	54.4	70	60.5	65.9	90

Model	9_26		
	FLA	MCA	MFS
Reheat/Humidifier Option			
Electric (30kW)/Boiler	109.9	126.8	130
Electric (30kW)/None	109.9	126.8	130
None, Non-electric/Boiler	74.7	82.7	100
None, Non-electric/None	64.4	69.8	90

## Chilled Water Systems

Model	9CU/CD14			9CU/CD16			9CU/CD18			9CU/CD20			9CU/CD22		
	FLA	MCA	MFS	FLA	MCA	MFS	FLA	MCA	MFS	FLA	MCA	MFS	FLA	MCA	MFS
Reheat/Humidifier Option															
Electric (24kW)/Boiler	52.3	61.9	70	55.1	65.4	70	55.1	65.4	70	58.7	69.9	80	58.7	69.9	80
Electric (24kW)/None	41.9	51.6	60	44.7	55.1	60	44.7	55.1	60	48.3	59.6	70	48.3	59.6	70
Electric (12kW)/Boiler	34.0	39.1	45	36.8	42.6	50	36.8	42.6	50	40.5	47.3	50	40.5	47.3	50
Electric (12kW)/None	23.7	28.8	35	26.4	32.2	40	26.5	32.3	40	30.2	36.9	45	30.2	36.9	45
None, Non-electric/Boiler	15.8	18.9	20	18.6	22.4	25	18.6	22.4	25	22.3	27.0	30	22.3	27.0	30
None, Non-electric/None	5.5	6.0	15	8.3	9.5	15	8.3	9.5	15	12.0	14.1	20	12.0	14.1	20

Model	9CU/CD25			9CU/CD26			9CU/CD30		
	FLA	MCA	MFS	FLA	MCA	MFS	FLA	MCA	MFS
Reheat/Humidifier Option									
Electric (30kW)/Boiler	71.7	86.2	100	71.7	86.2	100	71.7	86.2	100
Electric (30kW)/None	61.3	75.9	90	61.3	75.9	90	61.3	75.9	90
None, Non-electric/Boiler	26.1	31.8	35	26.1	31.8	35	26.1	31.8	35
None, Non-electric/None	15.8	18.9	20	15.8	18.9	20	15.8	18.9	20

\* Above FLA does not include air-cooled condenser amps (Air Dual cooled units).

† FLA is based on full load current of individual components that result in maximum electrical load condition during unit normal operation.  
 FLA = Full Load Amps                      MCA = Minimum Circuit Ampacity                      MFS = Maximum Fuse Size

**380V/3PH/50Hz**

**Dual / Free Cooled Systems\*†**

Model	9_06			9_08			9_12		
	FLA	MCA	MFS	FLA	MCA	MFS	FLA	MCA	MFS
Electric (12kW)/Boiler	33.6	39.1	45	38.9	44.8	50	46.5	52.9	60
Electric (12kW)/None	33.6	39.1	45	38.9	44.8	50	46.5	52.9	60
Electric (6kW)/Boiler	25.8	29.3	35	31.0	35.2	40	38.6	43.0	50
Electric (6kW)/None	24.6	27.8	30	29.8	33.5	35	37.4	41.5	45
None, Non-electric/Boiler	25.8	29.3	35	31.0	35.2	40	38.6	43.0	50
None, Non-electric/None	15.5	16.4	20	20.7	22.1	30	28.3	30.1	40

Model	9_14			9_16			9_18			9_20			9_22		
	FLA	MCA	MFS	FLA	MCA	MFS	FLA	MCA	MFS	FLA	MCA	MFS	FLA	MCA	MFS
Electric (24kW)/Boiler	73.1	85.1	90	79.3	92.1	100	82.9	95.7	100	86.7	100.0	110	96.9	111.5	120
Electric (24kW)/None	73.1	85.1	90	79.3	92.1	100	82.9	95.7	100	86.7	100.0	110	96.9	111.5	120
Electric (12kW)/Boiler	54.9	62.3	70	61.0	69.2	80	64.8	73.0	80	68.6	77.3	90	78.8	88.8	100
Electric (12kW)/None	54.9	62.3	70	61.0	69.2	80	64.8	73.0	80	68.6	77.3	90	78.8	88.8	100
None, Non-electric/Boiler	47.0	52.5	60	53.2	59.4	70	56.9	63.1	70	60.6	67.3	80	70.8	78.8	100
None, Non-electric/None	36.7	39.6	50	42.9	46.5	60	46.6	50.2	60	50.3	54.4	70	60.5	65.9	90

Model	9_26		
	FLA	MCA	MFS
Electric (30kW)/Boiler	109.9	126.8	130
Electric (30kW)/None	109.9	126.8	130
None, Non-electric/Boiler	74.7	82.7	100
None, Non-electric/None	64.4	69.8	90

\* Above FLA does not include air-cooled condenser amps (Air Dual cooled units).

† FLA is based on full load current of individual components that result in maximum electrical load condition during unit normal operation.  
 FLA = Full Load Amps                      MCA = Minimum Circuit Ampacity                      MFS = Maximum Fuse Size



## Dimensional Drawings

<b>Drawing Title</b>	<b>Drawing Number</b>	<b>Page No</b>
Upflow System - Standard Cooling Three Module Unit (14-22 Ton)	S9DD301B	48
Upflow System – Standard Cooling Four Module Unit (26 Ton)	S9DD401C	49
Upflow System – Standard Cooling Two Module Unit (6-12 Ton)	S9DD201A	4:
Upflow System – Chilled water Cooling (3+0) Module (14-25 Ton)	S9DD351A	4;
Upflow System – Chilled water Cooling (4+0) Module (26-30 Ton)	S9DD451A	52
Downflow System – Standard Cooling Three Module Unit (14-22 Ton)	S9DD302B	33
Downflow System – Standard Cooling Four Module Unit (26 Ton)	S9DD402C	34
Downflow System – Standard Cooling Two Module Unit (6-12 Ton)	S9DD202A	35
Downflow System – Chilled water Cooling (3+0) Module (14-25 Ton)	S9DD352C	36
Downflow System – Chilled water Cooling (4+0) Module (26-30 Ton)	S9DD452C	37
Upflow System - Rear Duct Connection (14-22 Ton)	S9DD303B	58
Upflow System - Rear Duct Connection (6-12 Ton)	S9DD203A	59
Upflow System – Rear Duct Connection (26 Ton)	S9DD403B	5:
Upflow System - Dual/Free Cooling (14-22 Ton)	S9DD325A	5;
Upflow System - Dual/Free Cooling (6-12 Ton)	S9DD225A	42
Downflow System - Dual/Free Cooling (14-22 Ton)	S9DD326A	43
Downflow System - Dual/Free Cooling (6-12 Ton)	S9DD226A	44
Upflow System - Rear Duct Connection, Dual/Free Cooling (14-22 Ton)	S9DD327A	45
Upflow System - Rear Duct Connection, Dual/Free Cooling (6-12 Ton)	S9DD227A	46



**SERIES 9-VERTICAL FLOOR MOUNT UPFLOW UNIT  
STANDARD COOLING THREE MODULE UNIT**

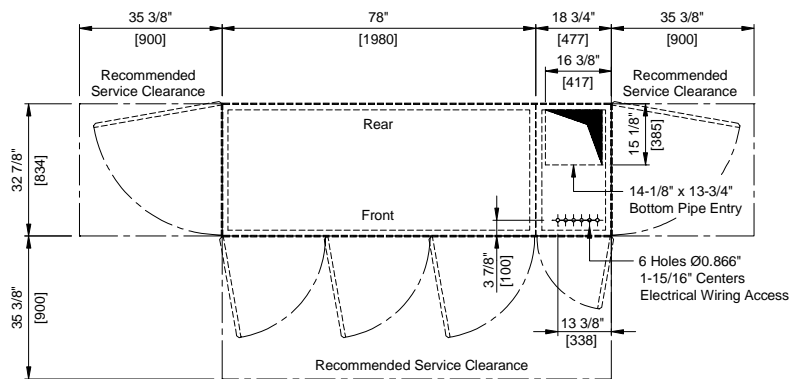
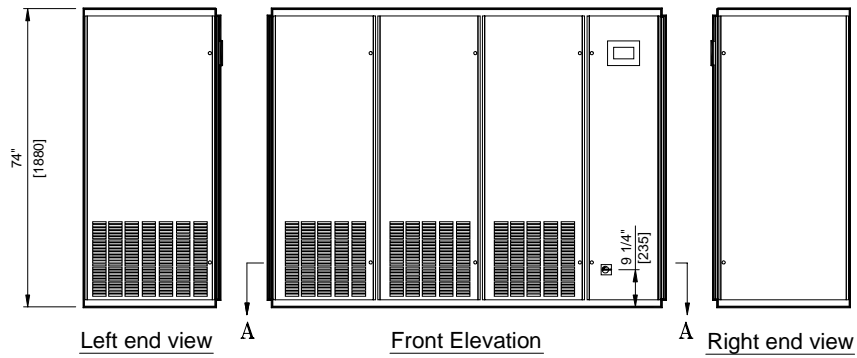
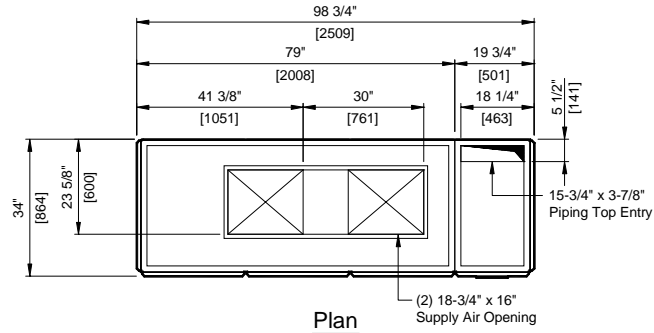

PIPING CONNECTION SIZE		14	16	18	20	22	*25
MODEL NO. SUFFIX							
Liquid Refrigerant	-ODM in	5/8	5/8	5/8	5/8	5/8	-
Hot Gaseous Refrigerant	-ODM in	1-1/8	1-1/8	1-1/8	1-1/8	1-1/8	-
Hot Water	-ODM in	1	1	1-1/8	1-1/8	1-1/8	7/8
Steam	-MPT in	7/8	7/8	7/8	7/8	7/8	7/8
Steam Condensate	-ODM in	3/4	3/4	3/4	3/4	3/4	3/4
Humidifier Water	-ODM in	1/4	1/4	1/4	1/4	1/4	1/4
Cooling Coil Condensate	-ODM in	3/4	3/4	3/4	3/4	3/4	3/4
Chilled Water	-ODM in	1-5/8	1-5/8	2-1/8	2-1/8	2-1/8	2-1/8
Condensing Water	-ODM in	1-3/8	1-3/8	1-3/8	1-3/8	1-5/8	-
Glycol Solution	-ODM in	2-1/8	2-1/8	2-1/8	2-1/8	2-1/8	-

ODM - Outside Diameter of copper pipe in inches for soldering    MPT - Male Pipe Thread    \* - Chilled Water Only



**SERIES 9-VERTICAL FLOOR MOUNT UPFLOW UNIT  
STANDARD COOLING FOUR MODULE UNIT**

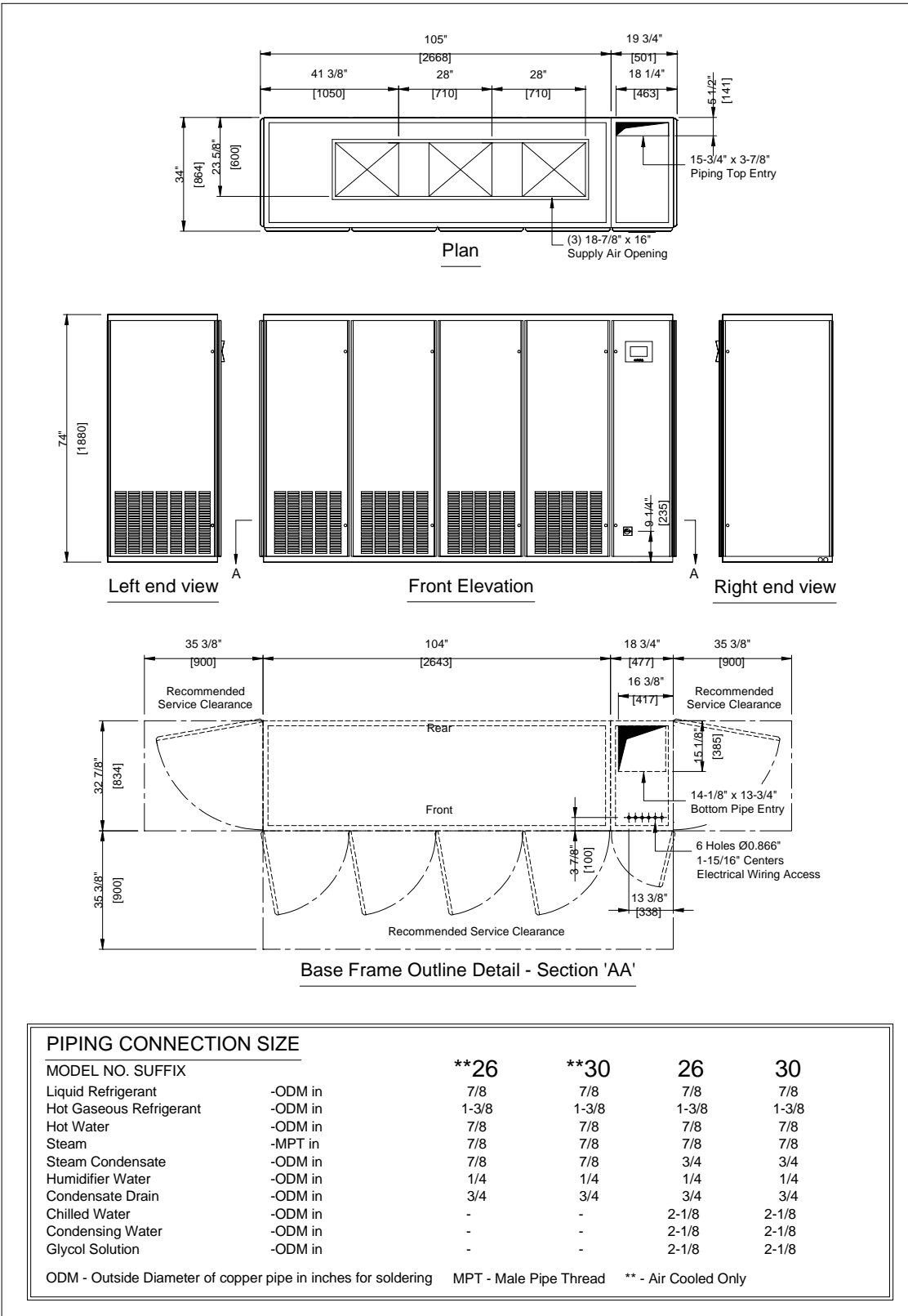

PIPING CONNECTION SIZE		**26	**30	26	30
MODEL NO. SUFFIX					
Liquid Refrigerant	-ODM in	7/8	7/8	7/8	7/8
Hot Gaseous Refrigerant	-ODM in	1-3/8	1-3/8	1-3/8	1-3/8
Hot Water	-ODM in	7/8	7/8	7/8	7/8
Steam	-MPT in	7/8	7/8	7/8	7/8
Steam Condensate	-ODM in	7/8	7/8	3/4	3/4
Humidifier Water	-ODM in	1/4	1/4	1/4	1/4
Condensate Drain	-ODM in	3/4	3/4	3/4	3/4
Chilled Water	-ODM in	-	-	2-1/8	2-1/8
Condensing Water	-ODM in	-	-	2-1/8	2-1/8
Glycol Solution	-ODM in	-	-	2-1/8	2-1/8

ODM - Outside Diameter of copper pipe in inches for soldering MPT - Male Pipe Thread \*\* - Air Cooled Only



**SERIES 9- VERTICAL FLOOR MOUNT UPFLOW UNIT  
STANDARD COOLING TWO MODULE UNIT**

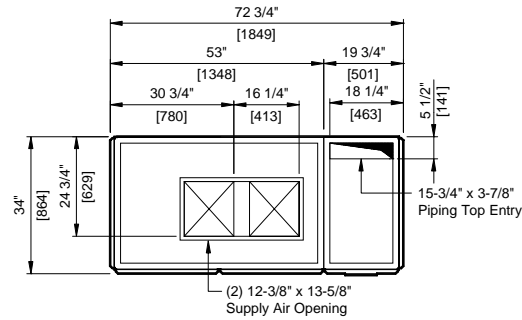

**Plan**

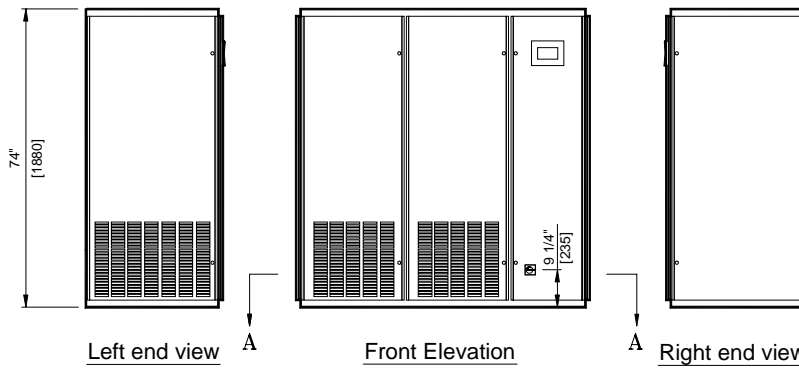

**Base Frame Outline Detail - Section 'AA'**

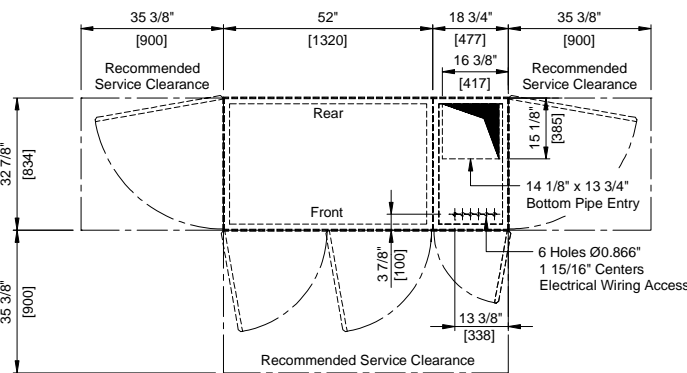

<b>PIPING CONNECTION SIZE</b>		<b>06</b>	<b>08</b>	<b>12</b>
MODEL NO. SUFFIX				
Liquid Refrigerant	-ODM in	1/2	1/2	1/2
Hot Gaseous Refrigerant	-ODM in	7/8	7/8	7/8
Hot Water	-ODM in	3/4	1	1
Steam	-MPT in	7/8	7/8	7/8
Steam Condensate	-ODM in	3/4	3/4	3/4
Humidifier Water	-ODM in	1/4	1/4	1/4
Cooling Coil Condensate	-ODM in	3/4	3/4	3/4
Chilled Water	-ODM in	1-1/8	1-1/8	1-5/8
Condensing Water	-ODM in	1-1/8	1-1/8	1-3/8
Glycol Solution	-ODM in	1-5/8	1-5/8	2-1/8

ODM - Outside Diameter of copper pipe in inches for soldering      MPT - Male Pipe Thread



**SERIES 9- VERTICAL FLOOR MOUNT UPFLOW UNIT  
CHILLED WATER COOLING (3 +0) MODULE**

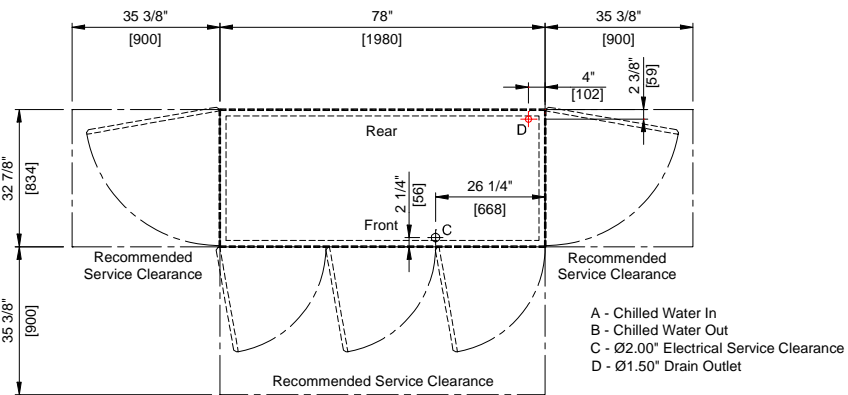
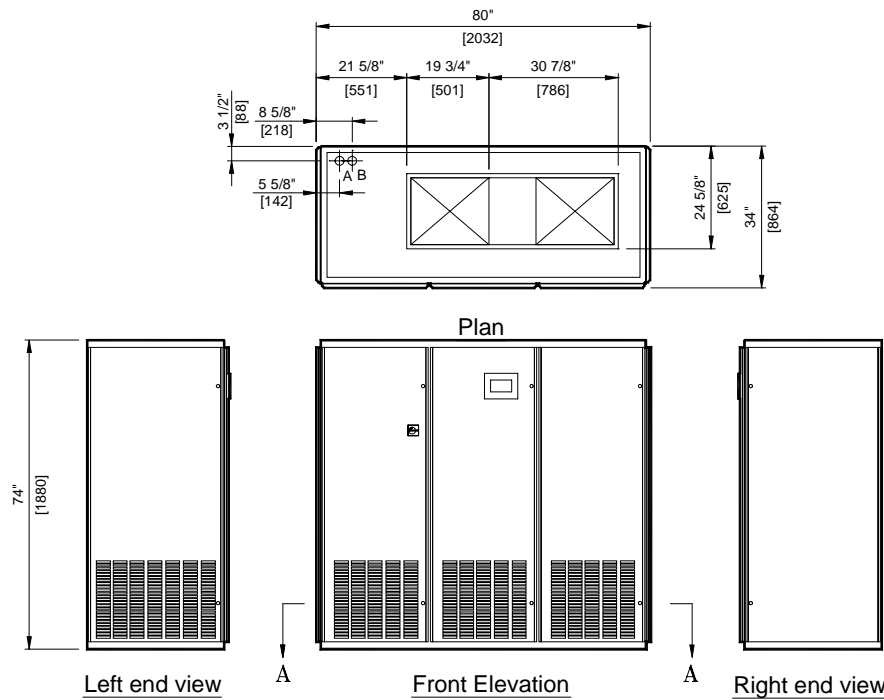

**Base Frame Outline Detail - Section 'AA'**

<b>PIPING CONNECTION SIZE</b>		14	16	18	20	22	*25
MODEL NO. SUFFIX							
Liquid Refrigerant	-ODM in	-	-	-	-	-	-
Hot Gaseous Refrigerant	-ODM in	-	-	-	-	-	-
Hot Water	-ODM in	1	1	1-1/8	1-1/8	1-1/8	7/8
Steam	-MPT in	7/8	7/8	7/8	7/8	7/8	7/8
Steam Condensate	-ODM in	3/4	3/4	3/4	3/4	3/4	3/4
Humidifier Water	-ODM in	1/4	1/4	1/4	1/4	1/4	1/4
Cooling Coil Condensate	-ODM in	3/4	3/4	3/4	3/4	3/4	3/4
Chilled Water	-ODM in	1-5/8	1-5/8	2-1/8	2-1/8	2-1/8	2-1/8
Condensing Water	-ODM in	-	-	-	-	-	-
Glycol Solution	-ODM in	-	-	-	-	-	-

ODM - Outside Diameter of copper pipe in inches for soldering    MPT - Male Pipe Thread



**SERIES 9-VERTICAL FLOOR MOUNT UPFLOW UNIT  
CHILLED WATER COOLING (4+0) MODULE**

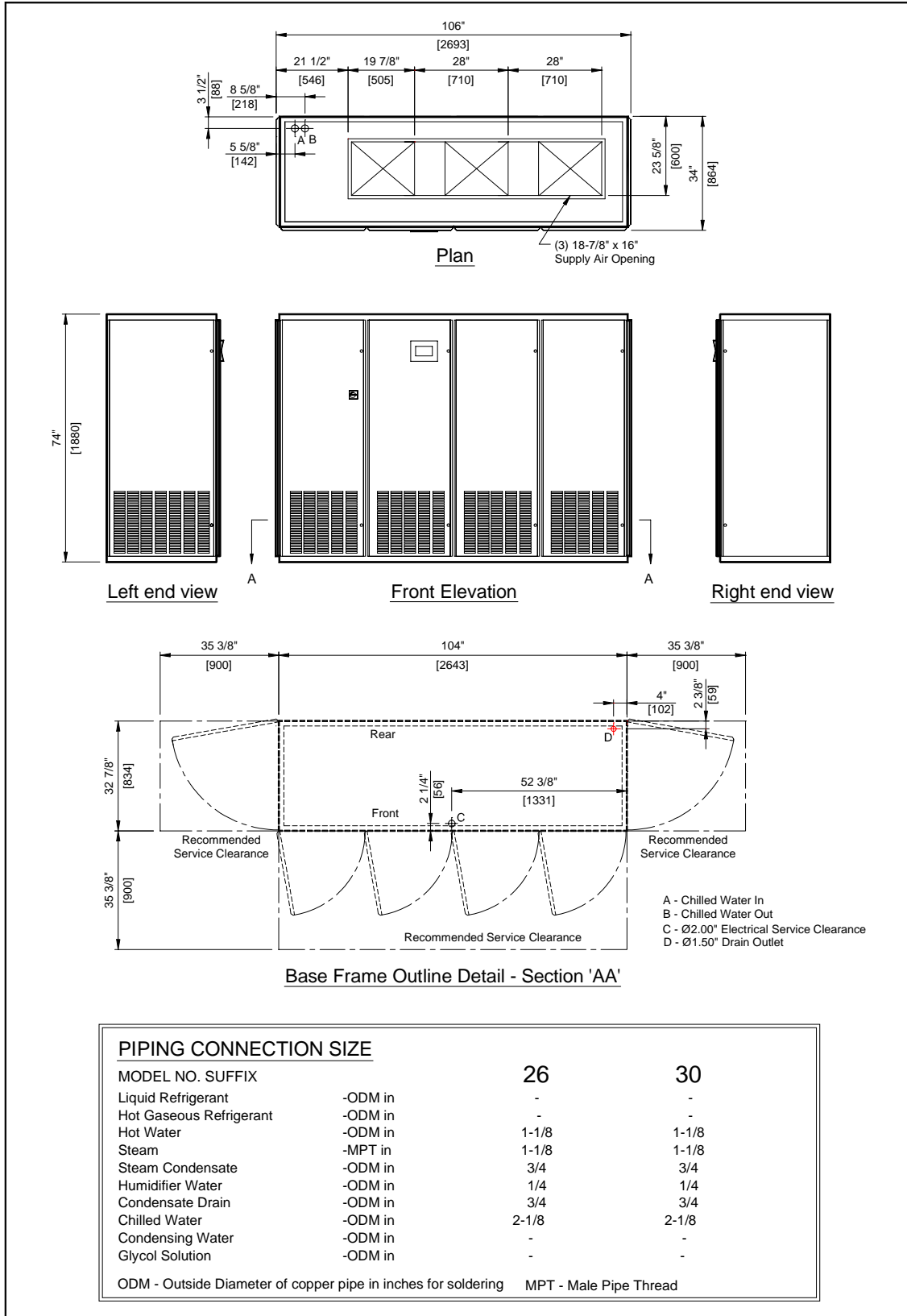

S9DD451A

25 March 2002

NOT TO SCALE



**SERIES 9-VERTICAL FLOOR MOUNT DOWNFLOW UNIT  
STANDARD COOLING THREE MODULE UNIT**

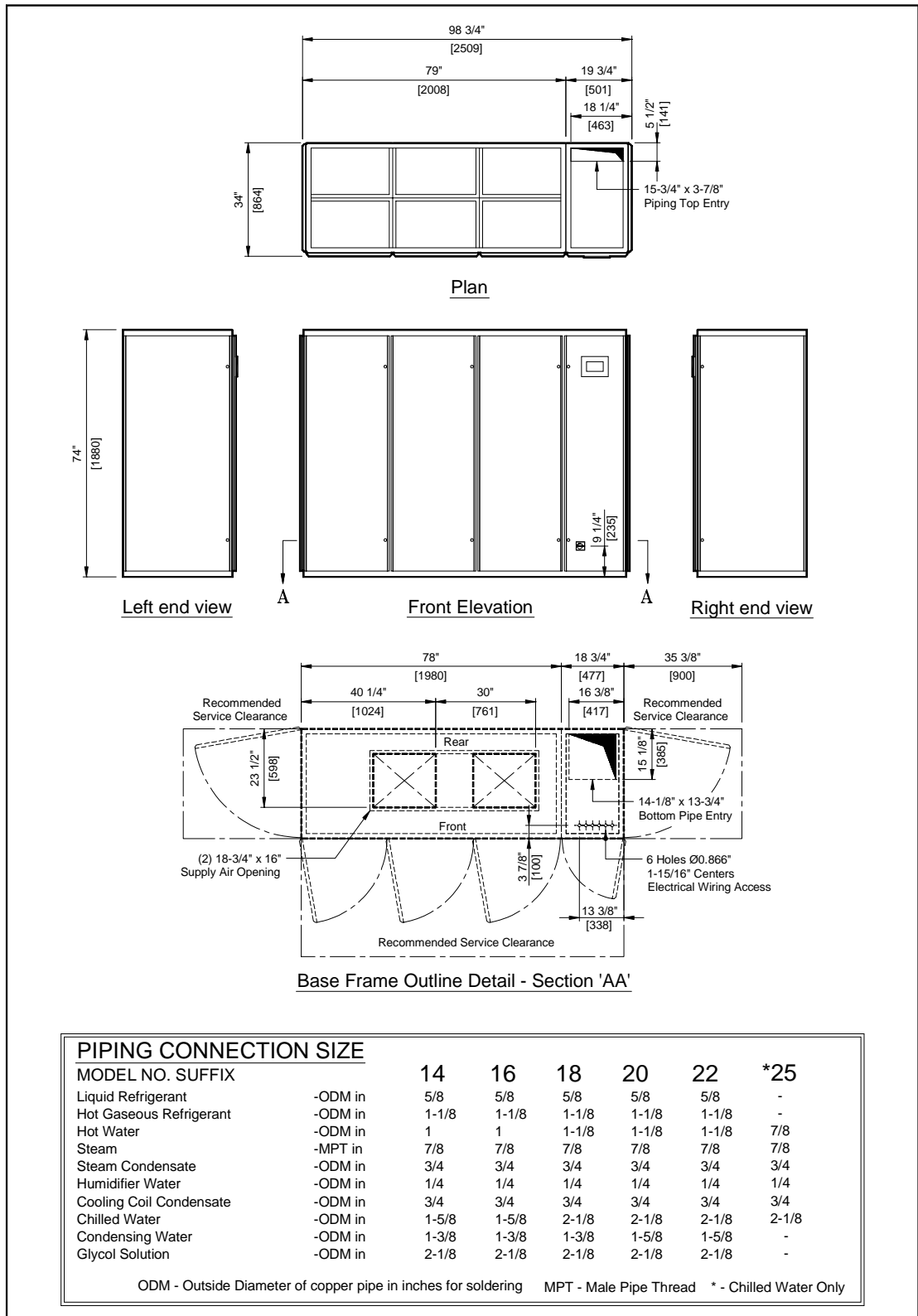

PIPING CONNECTION SIZE		14	16	18	20	22	*25
MODEL NO. SUFFIX							
Liquid Refrigerant	-ODM in	5/8	5/8	5/8	5/8	5/8	-
Hot Gaseous Refrigerant	-ODM in	1-1/8	1-1/8	1-1/8	1-1/8	1-1/8	-
Hot Water	-ODM in	1	1	1-1/8	1-1/8	1-1/8	7/8
Steam	-MPT in	7/8	7/8	7/8	7/8	7/8	7/8
Steam Condensate	-ODM in	3/4	3/4	3/4	3/4	3/4	3/4
Humidifier Water	-ODM in	1/4	1/4	1/4	1/4	1/4	1/4
Cooling Coil Condensate	-ODM in	3/4	3/4	3/4	3/4	3/4	3/4
Chilled Water	-ODM in	1-5/8	1-5/8	2-1/8	2-1/8	2-1/8	2-1/8
Condensing Water	-ODM in	1-3/8	1-3/8	1-3/8	1-5/8	1-5/8	-
Glycol Solution	-ODM in	2-1/8	2-1/8	2-1/8	2-1/8	2-1/8	-

ODM - Outside Diameter of copper pipe in inches for soldering MPT - Male Pipe Thread \* - Chilled Water Only



**SERIES 9-VERTICAL FLOOR MOUNT DOWNFLOW UNIT  
STANDARD COOLING FOUR MODULE UNIT**

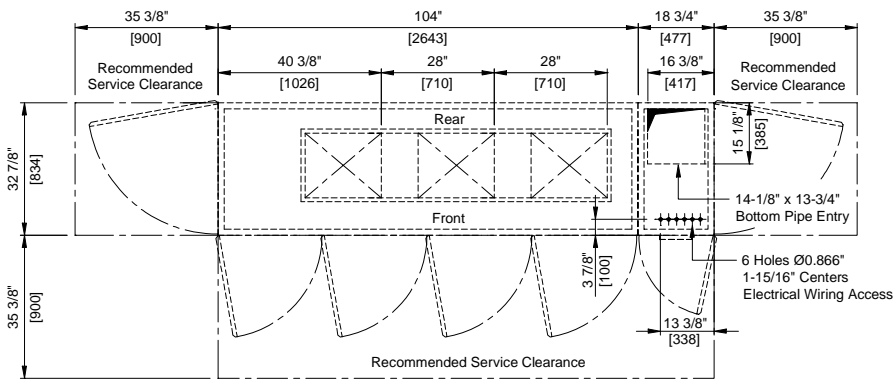
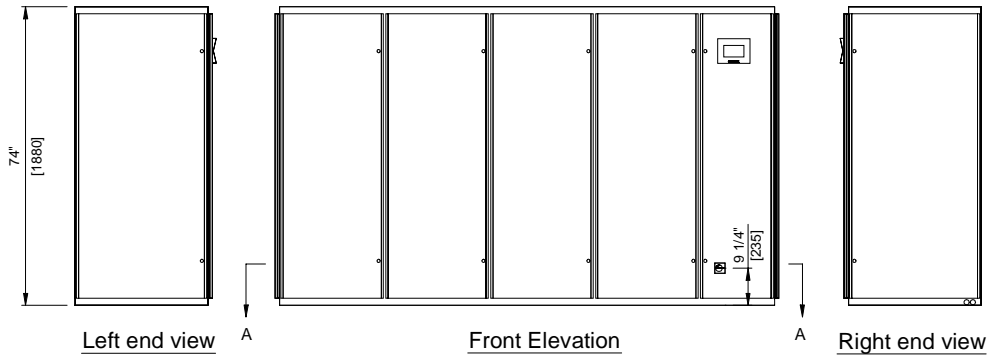
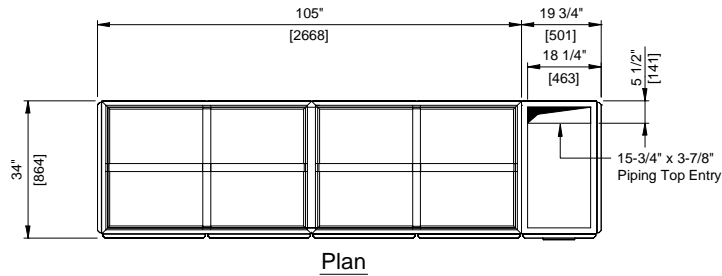

PIPING CONNECTION SIZE		**26	**30	26	30
MODEL NO. SUFFIX					
Liquid Refrigerant	-ODM in	7/8	7/8	7/8	7/8
Hot Gaseous Refrigerant	-ODM in	1-3/8	1-3/8	1-3/8	1-3/8
Hot Water	-ODM in	7/8	7/8	7/8	7/8
Steam	-MPT in	7/8	7/8	7/8	7/8
Steam Condensate	-ODM in	7/8	7/8	3/4	3/4
Humidifier Water	-ODM in	1/4	1/4	1/4	1/4
Condensate Drain	-ODM in	3/4	3/4	3/4	3/4
Chilled Water	-	-	-	2-1/8	2-1/8
Condensing Water	-	-	-	2-1/8	2-1/8
Glycol Solution	-	-	-	2-1/8	2-1/8

ODM - Outside Diameter of copper pipe in inches for soldering    MPT - Male Pipe Thread    \*\* - Air Cooled Only





**SERIES 9-VERTICAL FLOOR MOUNT DOWNFLOW UNIT  
STANDARD COOLING TWO MODULE UNIT**

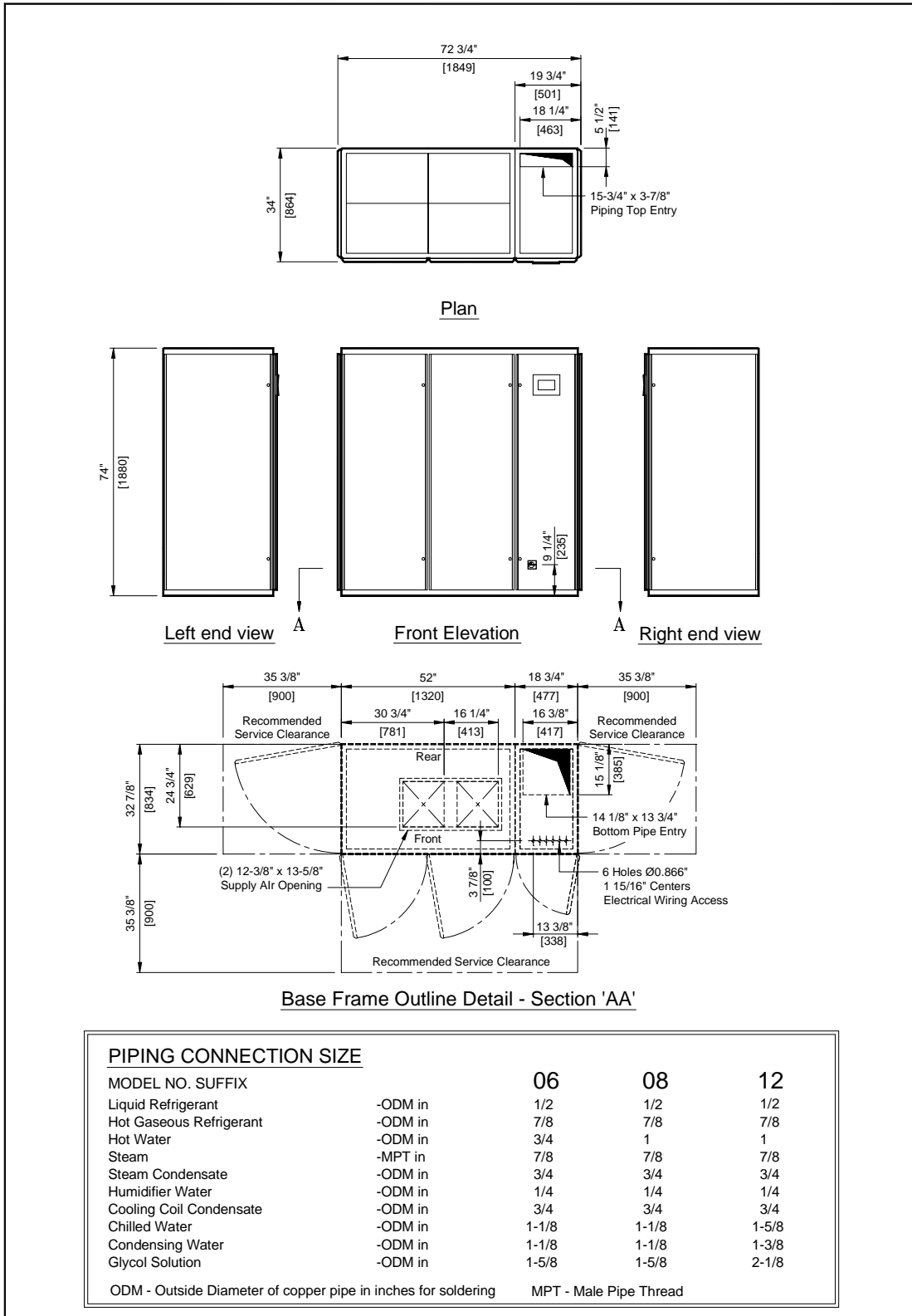

S9DD202A

28 November 2001

NOT TO SCALE



CLIMATEWORX  
INTERNATIONAL

**SERIES 9-VERTICAL FLOOR MOUNT DOWNFLOW UNIT  
CHILLED WATER COOLING (3+0) MODULE**

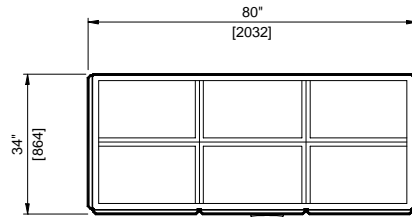

Plan

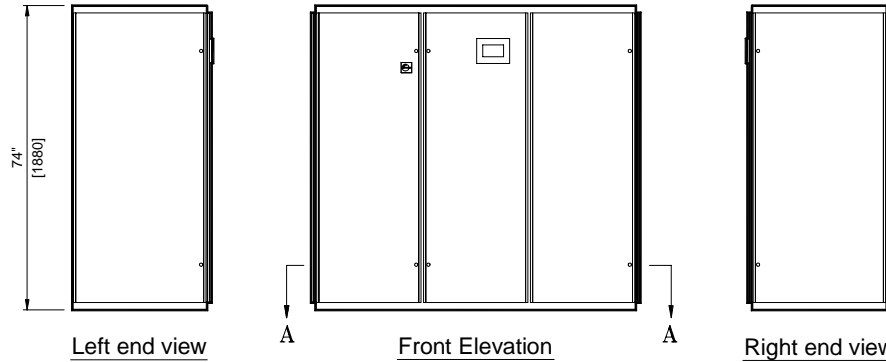

Left end view

Front Elevation

Right end view

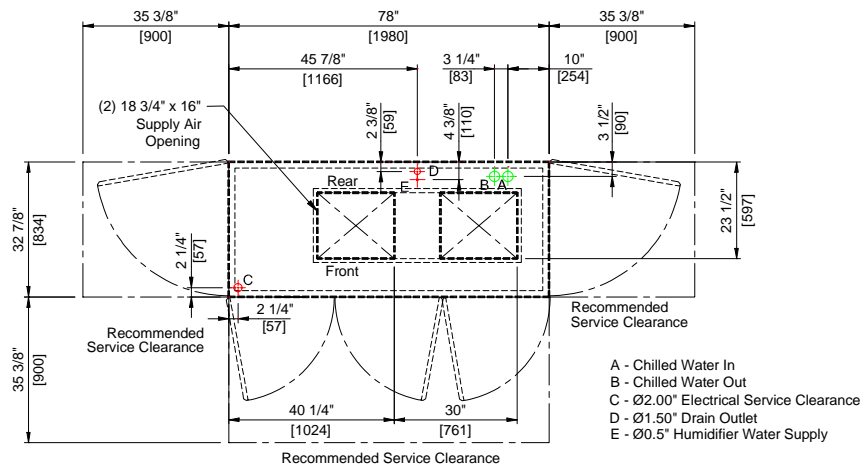

Base Frame Outline Detail - Section 'AA'

PIPING CONNECTION SIZE		14	16	18	20	22	*25
MODEL NO. SUFFIX							
Liquid Refrigerant	-ODM in	-	-	-	-	-	-
Hot Gaseous Refrigerant	-ODM in	-	-	-	-	-	-
Hot Water	-ODM in	1	1	1-1/8	1-1/8	1-1/8	1-1/8
Steam	-MPT in	7/8	7/8	7/8	7/8	7/8	7/8
Steam Condensate	-ODM in	3/4	3/4	3/4	3/4	3/4	3/4
Humidifier Water	-ODM in	1/4	1/4	1/4	1/4	1/4	1/4
Cooling Coil Condensate	-ODM in	3/4	3/4	3/4	3/4	3/4	3/4
Chilled Water	-ODM in	1-5/8	1-5/8	2-1/8	2-1/8	2-1/8	2-1/8
Condensing Water	-ODM in	-	-	-	-	-	-
Glycol Solution	-ODM in	-	-	-	-	-	-

ODM - Outside Diameter of copper pipe in inches for soldering    MPT - Male Pipe Thread



**SERIES 9-VERTICAL FLOOR MOUNT DOWNFLOW UNIT  
CHILLED WATER COOLING (4+0) MODULE**

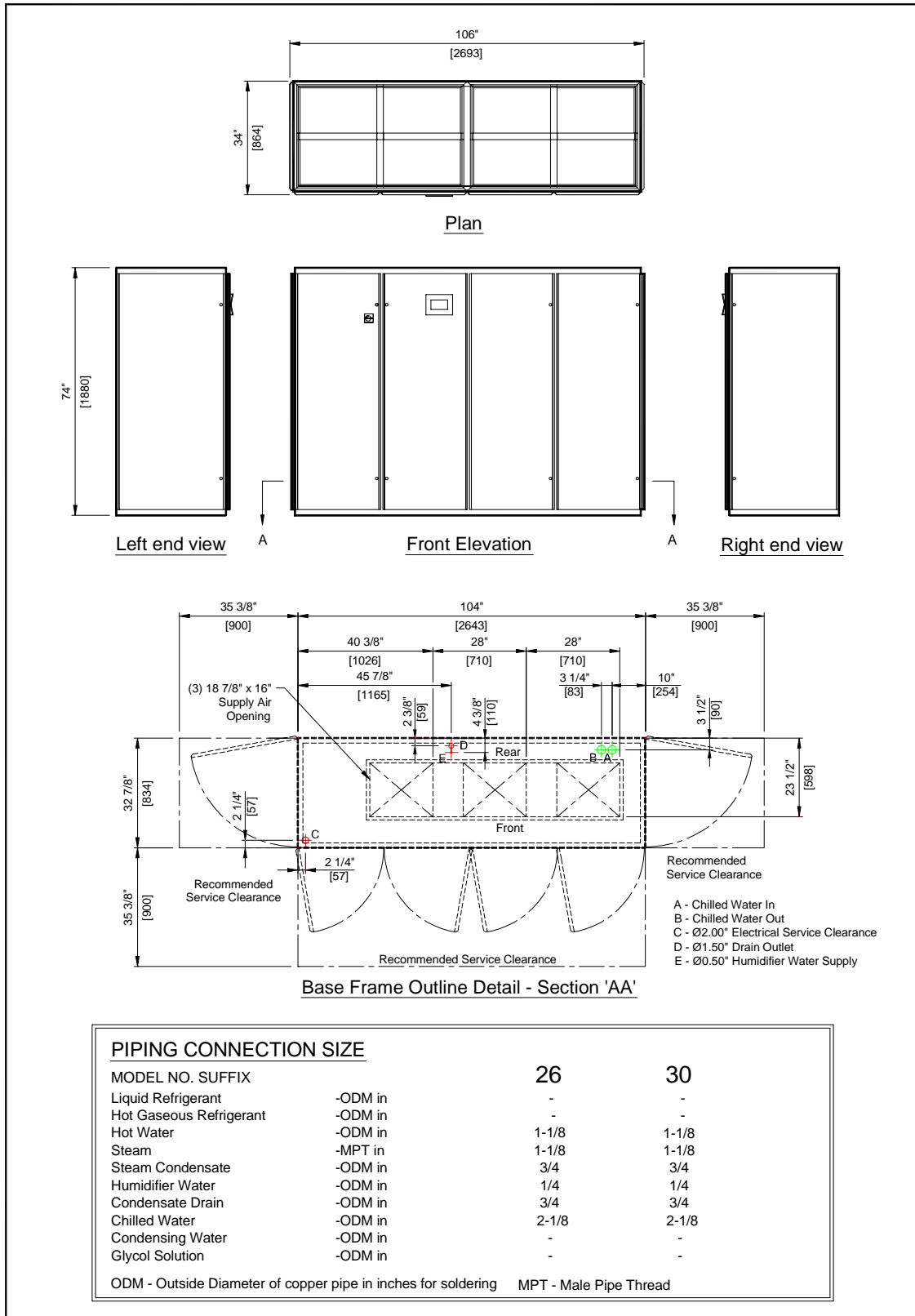

S9DD452C

24 JUNE, 2002

NOT TO SCALE





**SERIES 9- VERTICAL FLOOR MOUNT UPFLOW UNIT  
REAR RETURN STD. COOLING TWO MODULE UNIT**

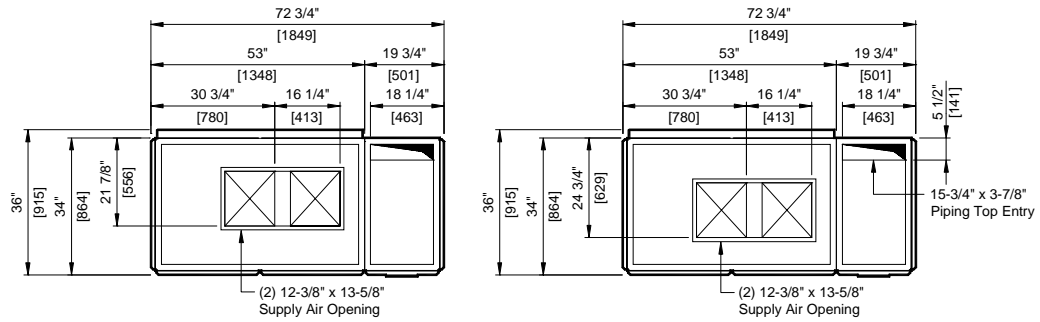

Plan (Back Discharge)

Plan (Front Discharge)

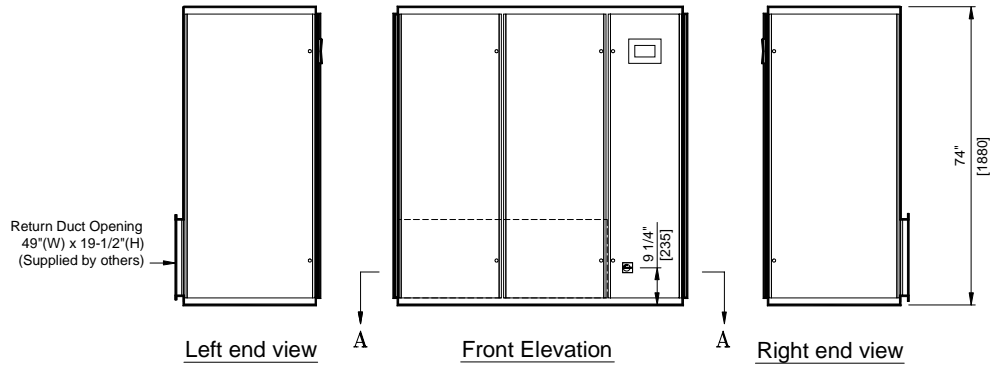

Left end view

Front Elevation

Right end view

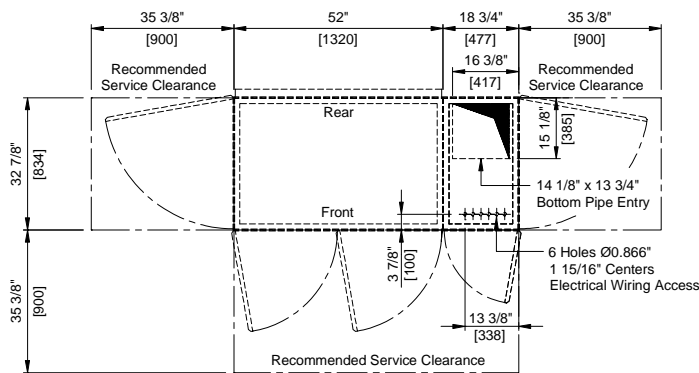

Base Frame Outline Detail - Section 'AA'

PIPING CONNECTION SIZE		06	08	12
MODEL NO. SUFFIX				
Liquid Refrigerant	-ODM in	1/2	1/2	1/2
Hot Gaseous Refrigerant	-ODM in	7/8	7/8	7/8
Hot Water	-ODM in	3/4	1	1
Steam	-MPT in	7/8	7/8	7/8
Steam Condensate	-ODM in	3/4	3/4	3/4
Humidifier Water	-ODM in	1/4	1/4	1/4
Cooling Coil Condensate	-ODM in	3/4	3/4	3/4
Chilled Water	-ODM in	1-1/8	1-1/8	1-5/8
Condensing Water	-ODM in	1-1/8	1-1/8	1-3/8
Glycol Solution	-ODM in	1-5/8	1-5/8	2-1/8

ODM - Outside Diameter of copper pipe in inches for soldering    MPT - Male Pipe Thread



**SERIES 9- VERTICAL FLOOR MOUNT UPFLOW UNIT  
REAR RETURN STD. COOLING FOUR MODULE UNIT**

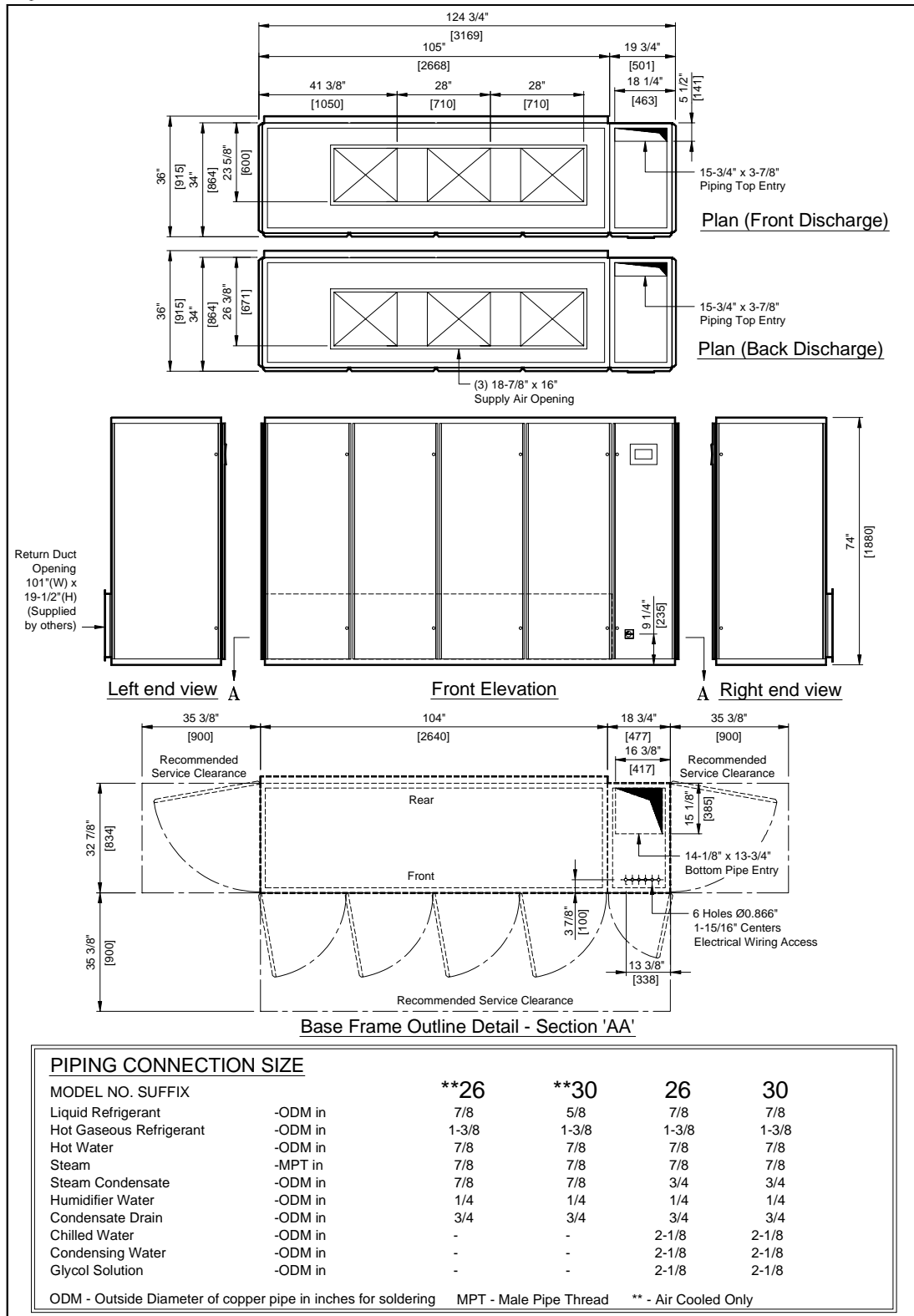

S9DD403B

07 February 2002

NOT TO SCALE



**SERIES 9-VERTICAL FLOOR MOUNT UPFLOW UNIT  
DUAL COOLING THREE MODULE UNIT**

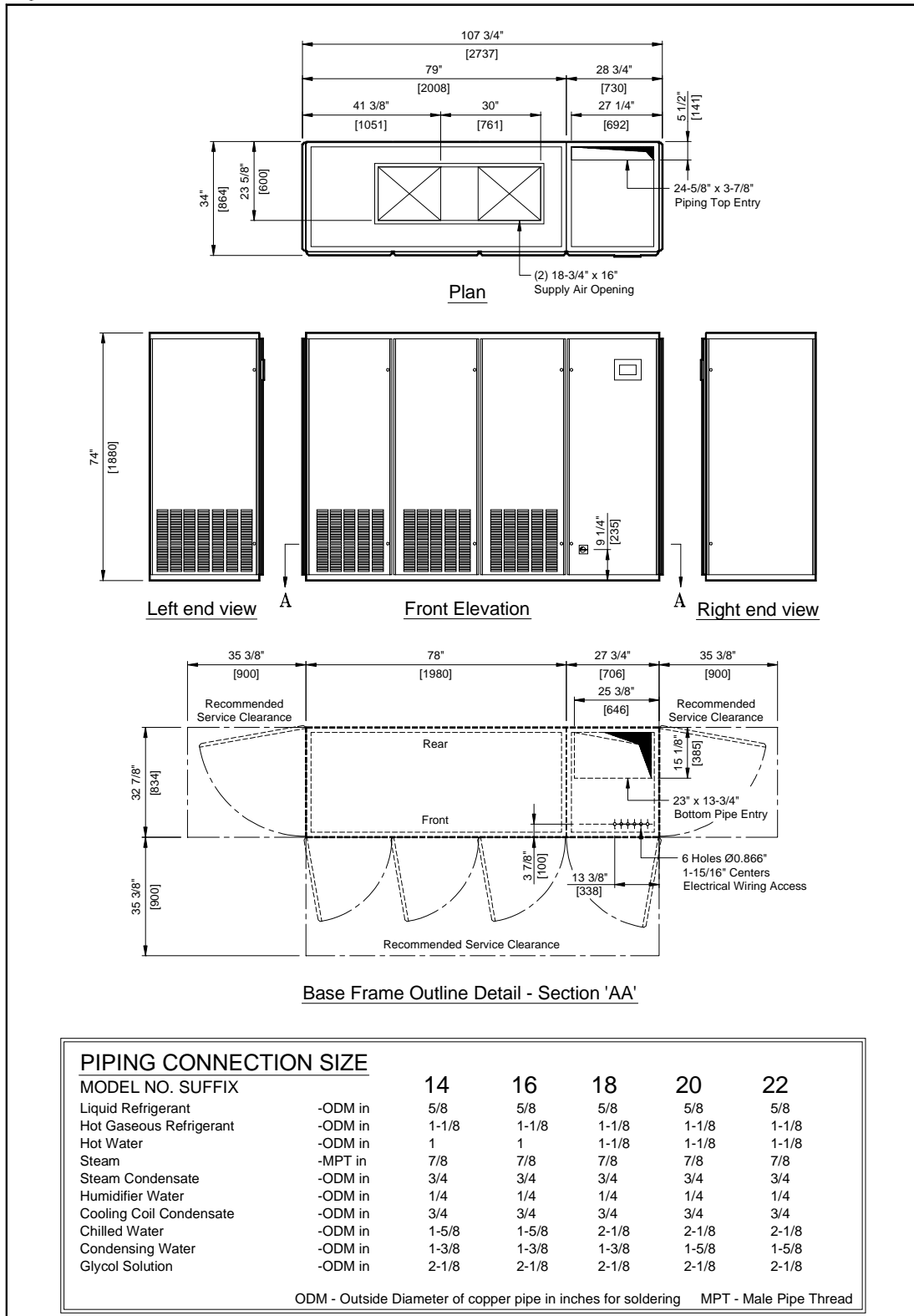

S9DD325A

29 November 2001

NOT TO SCALE



**SERIES 9- VERTICAL FLOOR MOUNT UPFLOW UNIT  
DUAL COOLING TWO MODULE UNIT**

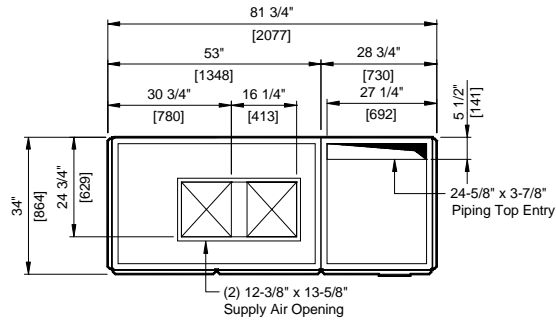

**Plan**

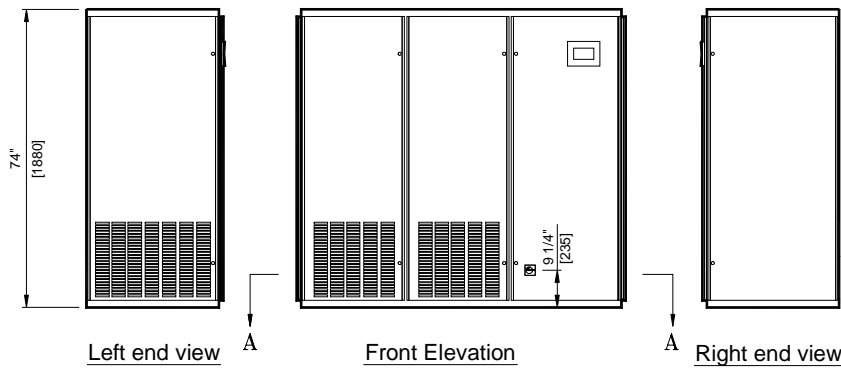

**Base Frame Outline Detail - Section 'AA'**

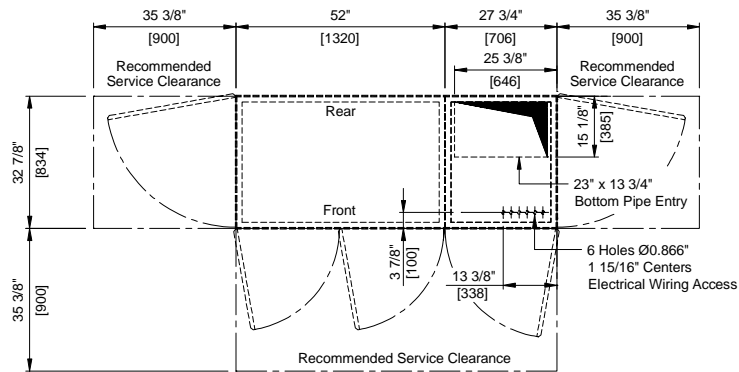

<b>PIPING CONNECTION SIZE</b>				
MODEL NO. SUFFIX		<b>06</b>	<b>08</b>	<b>12</b>
Liquid Refrigerant	-ODM in	1/2	1/2	1/2
Hot Gaseous Refrigerant	-ODM in	7/8	7/8	7/8
Hot Water	-ODM in	3/4	1	1
Steam	-MPT in	7/8	7/8	7/8
Steam Condensate	-ODM in	3/4	3/4	3/4
Humidifier Water	-ODM in	1/4	1/4	1/4
Cooling Coil Condensate	-ODM in	3/4	3/4	3/4
Chilled Water	-ODM in	1-1/8	1-1/8	1-5/8
Condensing Water	-ODM in	1-1/8	1-1/8	1-3/8
Glycol Solution	-ODM in	1-5/8	1-5/8	2-1/8

ODM - Outside Diameter of copper pipe in inches for soldering    MPT - Male Pipe Thread





**SERIES 9-VERTICAL FLOOR MOUNT DOWNFLOW UNIT  
DUAL COOLING THREE MODULE UNIT**

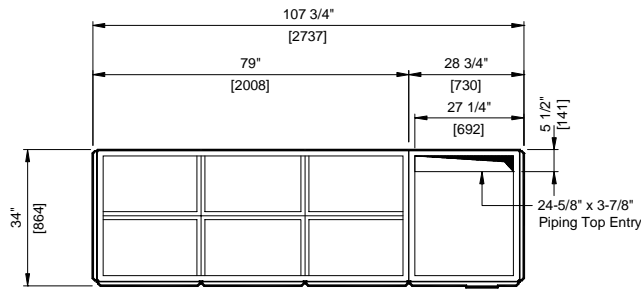

Plan

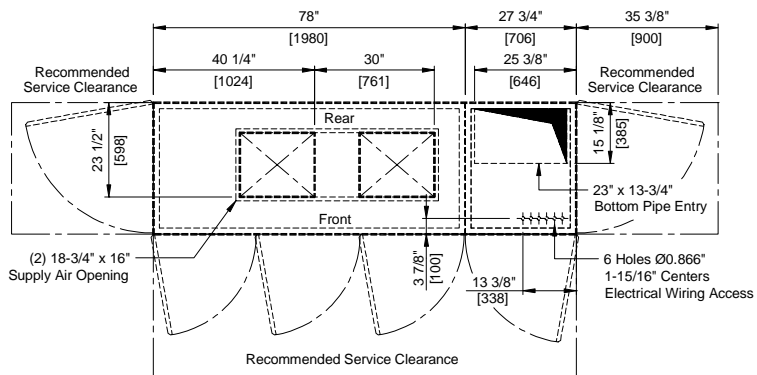
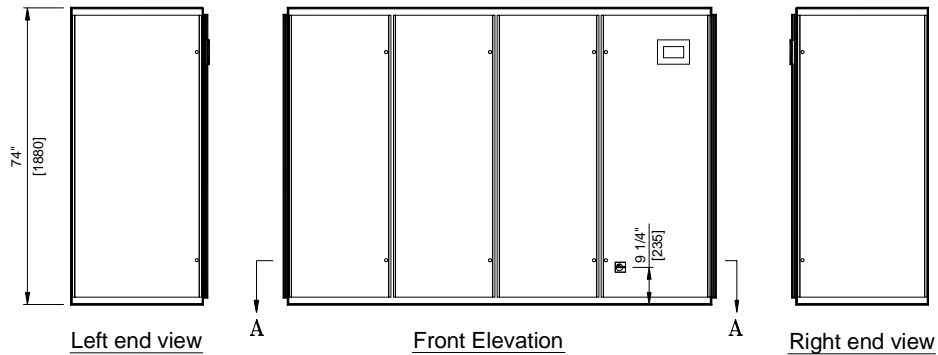

Base Frame Outline Detail - Section 'AA'

PIPING CONNECTION SIZE		14	16	18	20	22
MODEL NO.	SUFFIX					
Liquid Refrigerant	-ODM in	5/8	5/8	5/8	5/8	5/8
Hot Gaseous Refrigerant	-ODM in	1-1/8	1-1/8	1-1/8	1-1/8	1-1/8
Hot Water	-ODM in	1	1	1-1/8	1-1/8	1-1/8
Steam	-MPT in	7/8	7/8	7/8	7/8	7/8
Steam Condensate	-ODM in	3/4	3/4	3/4	3/4	3/4
Humidifier Water	-ODM in	1/4	1/4	1/4	1/4	1/4
Cooling Coil Condensate	-ODM in	3/4	3/4	3/4	3/4	3/4
Chilled Water	-ODM in	1-5/8	1-5/8	2-1/8	2-1/8	2-1/8
Condensing Water	-ODM in	1-3/8	1-3/8	1-3/8	1-5/8	1-5/8
Glycol Solution	-ODM in	2-1/8	2-1/8	2-1/8	2-1/8	2-1/8

ODM - Outside Diameter of copper pipe in inches for soldering    MPT - Male Pipe Thread



**SERIES 9-VERTICAL FLOOR MOUNT DOWNFLOW UNIT  
DUAL COOLING TWO MODULE UNIT**

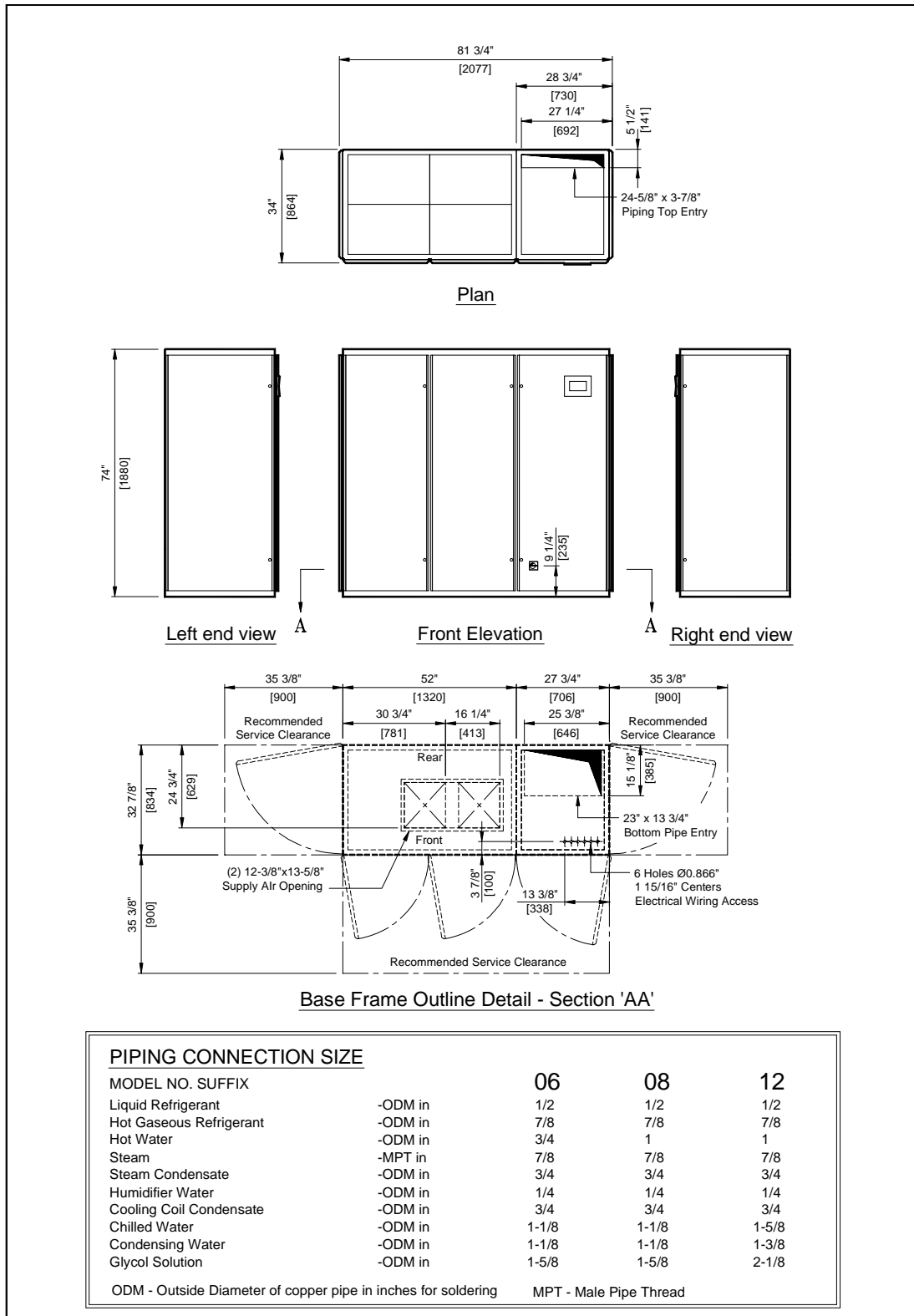

S9DD226A

28 November 2001

NOT TO SCALE

**CLIMATEWORX INTERNATIONAL** SERIES 9- VERTICAL FLOOR MOUNT UPFLOW UNIT  
**REAR RETURN DUAL COOLING THREE MODULE UNIT**

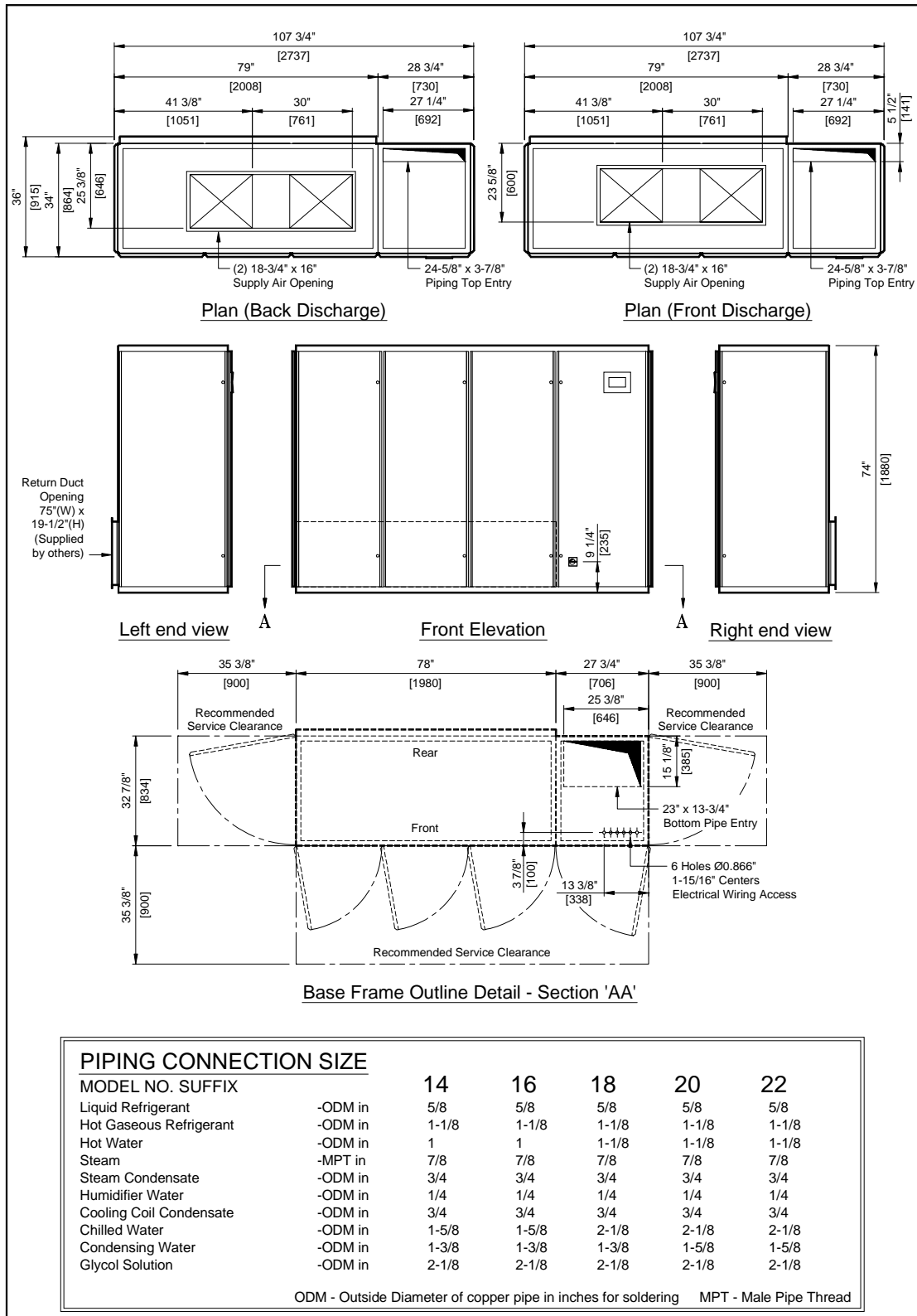

S9DD327A

28 November 2001

NOT TO SCALE



**SERIES 9- VERTICAL FLOOR MOUNT UPFLOW UNIT  
REAR RETURN DUAL COOLING TWO MODULE UNIT**

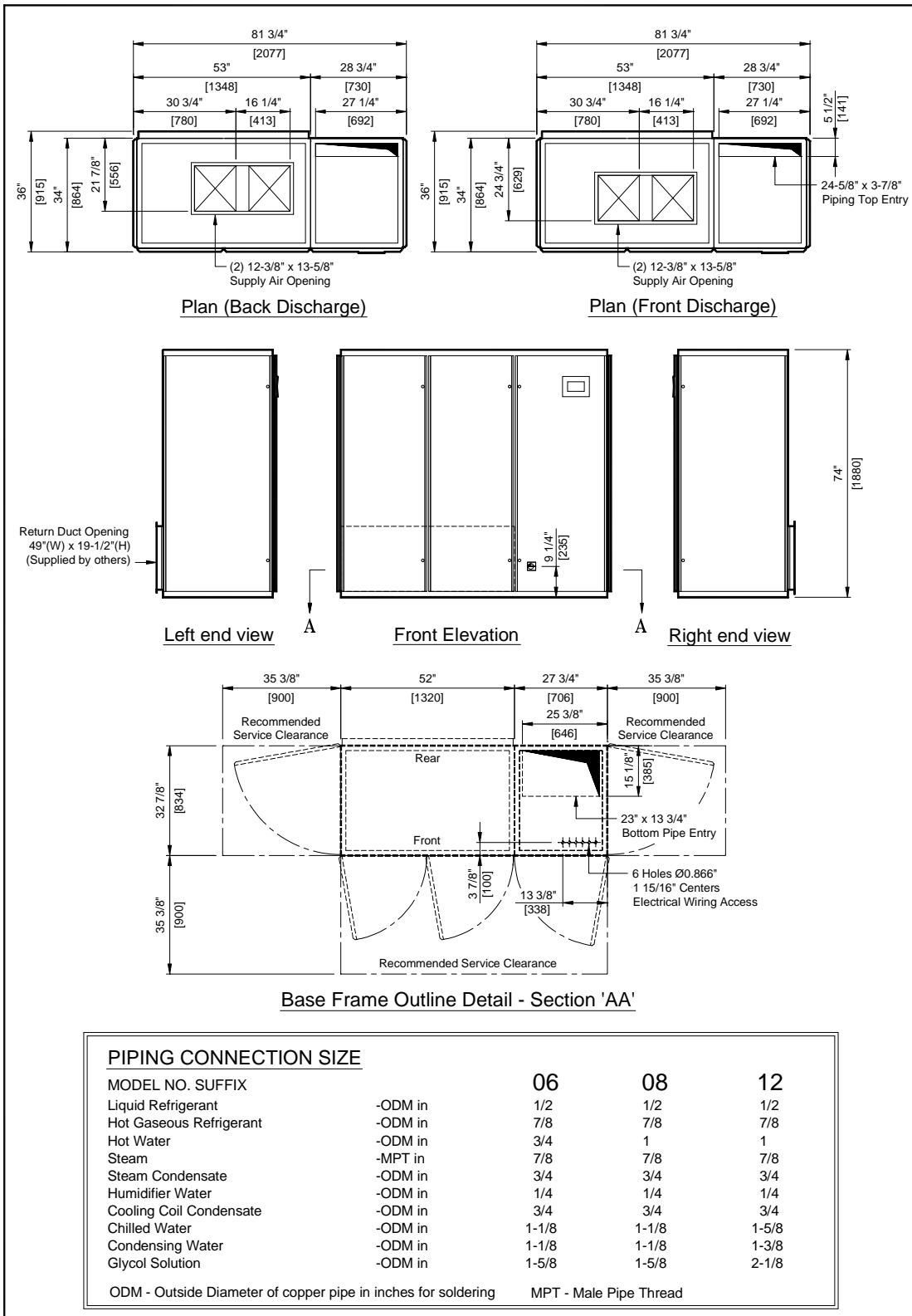

**PIPING CONNECTION SIZE**

MODEL NO. SUFFIX		06	08	12
Liquid Refrigerant	-ODM in	1/2	1/2	1/2
Hot Gaseous Refrigerant	-ODM in	7/8	7/8	7/8
Hot Water	-ODM in	3/4	1	1
Steam	-MPT in	7/8	7/8	7/8
Steam Condensate	-ODM in	3/4	3/4	3/4
Humidifier Water	-ODM in	1/4	1/4	1/4
Cooling Coil Condensate	-ODM in	3/4	3/4	3/4
Chilled Water	-ODM in	1-1/8	1-1/8	1-5/8
Condensing Water	-ODM in	1-1/8	1-1/8	1-3/8
Glycol Solution	-ODM in	1-5/8	1-5/8	2-1/8

ODM - Outside Diameter of copper pipe in inches for soldering    MPT - Male Pipe Thread