

DATE PRINTED: 4/9/2013

REVISIONS			
REV.	DESCRIPTION	DATE	APPROVED
-	-	-	-
-	-	-	-

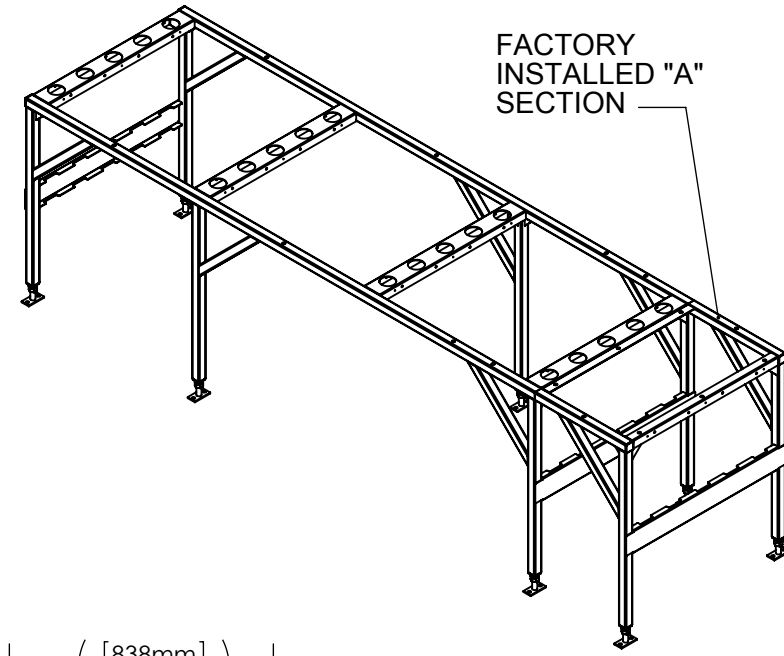

NOTES:

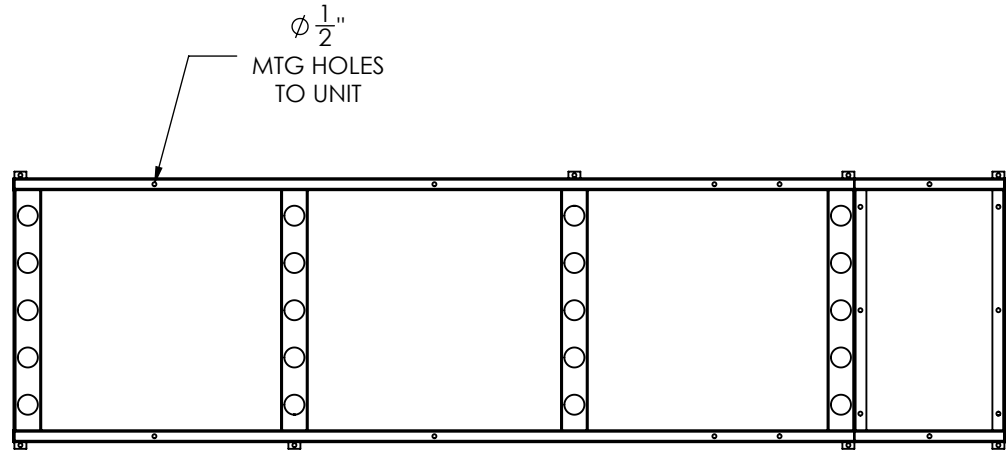
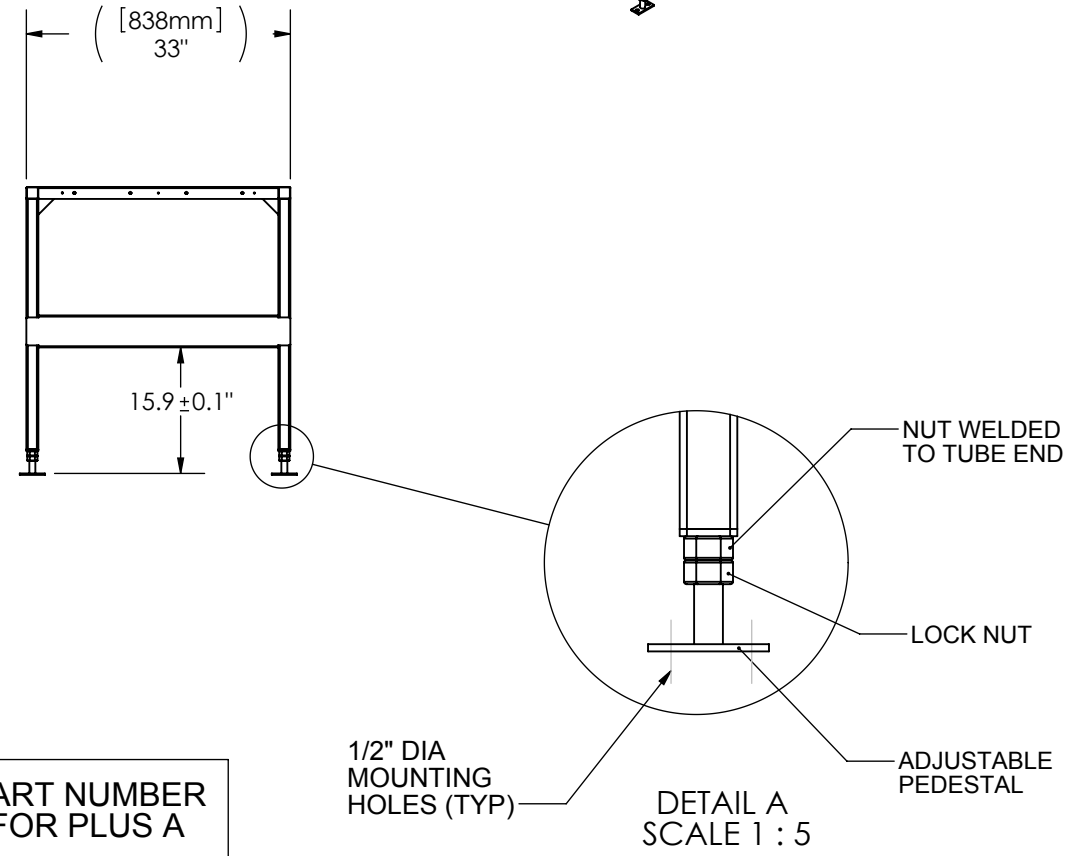
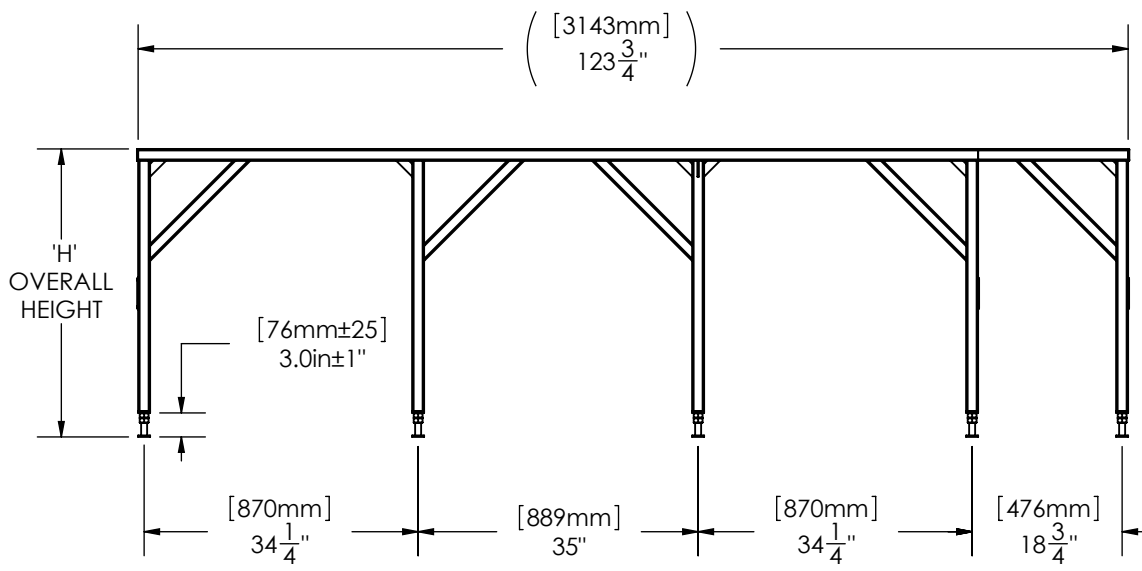

NOTES:

FLOORSTAND MATERIAL:
STRUCTURAL STEEL TUBE 1.5"x1.5"x1/8" WALL THICKNESS

FLOORSTAND FINISH:
BLACK SMOOTH POWDERCOAT

OVERALL HEIGHT:
MODEL AS SHOWN, SEE TABLE. OTHER HEIGHTS MAY NOT BE AS SHOWN AND MAY BE ON A DIFFERENT DRAWING. HEIGHTS NOT LISTED AVAILABLE ON REQUEST.

OVERALL HEIGHT "H"	PART NUMBER	PART NUMBER FOR PLUS A
36"	780-100-0105	780-100-0098

UNLESS OTHERWISE SPECIFIED DIMENSIONS ARE IN INCHES
TOLERANCES:
FRACTIONAL ± 1/8
ANGULAR: ± 0.5° BEND ± 2°
DECIMAL
XXX = ± .010
XX = ± .020
X = ± .030
HOLE DIA. +.003/- .000

	BY	DATE
DRAWN	PS	08/31/2009
CHECKED	IZ	08/31/2009
CNC PROGRAM		
FINISH:	BLACK SMOOTH POWDERCOAT	
MATERIAL	N/A	THICKNESS N/A

FINAL ASSEMBLY FLOOR STAND 36", PLUS A	
SUBMITTAL DRAWING	
PART NAME SEE TABLE	
SIZE DWG. NO.	SPDF-HPA-36
REV. SEE TABLE	
BD N/A	K
SCALE: 1:20	SHEET 1 OF 1

CONFIDENTIAL: THE COPYRIGHT OF THIS DOCUMENT IS RESERVED BY CLIMATEWORX. THIS DOCUMENT IS ISSUED ON THE CONDITION THAT IT IS NOT COPIED, REPRODUCED OR DISCLOSED TO ANY OTHER PARTY WITHOUT WRITTEN CONSENT OF CLIMATEWORX.

