

DATE PRINTED: 2/24/2017

REVISIONS			
REV.	DESCRIPTION	DATE	APPROVED
-	-	-	-
-	-	-	-

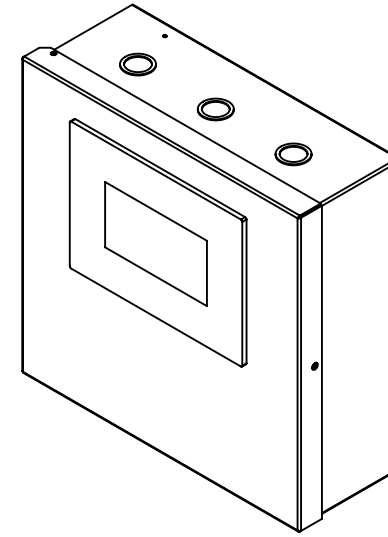

NOTES:

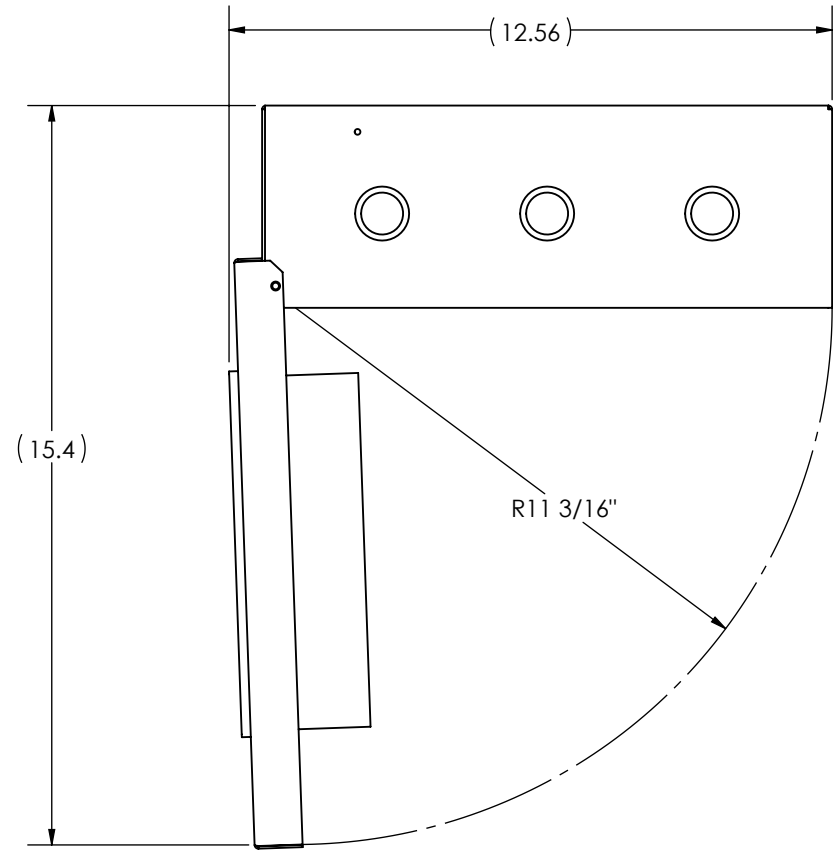
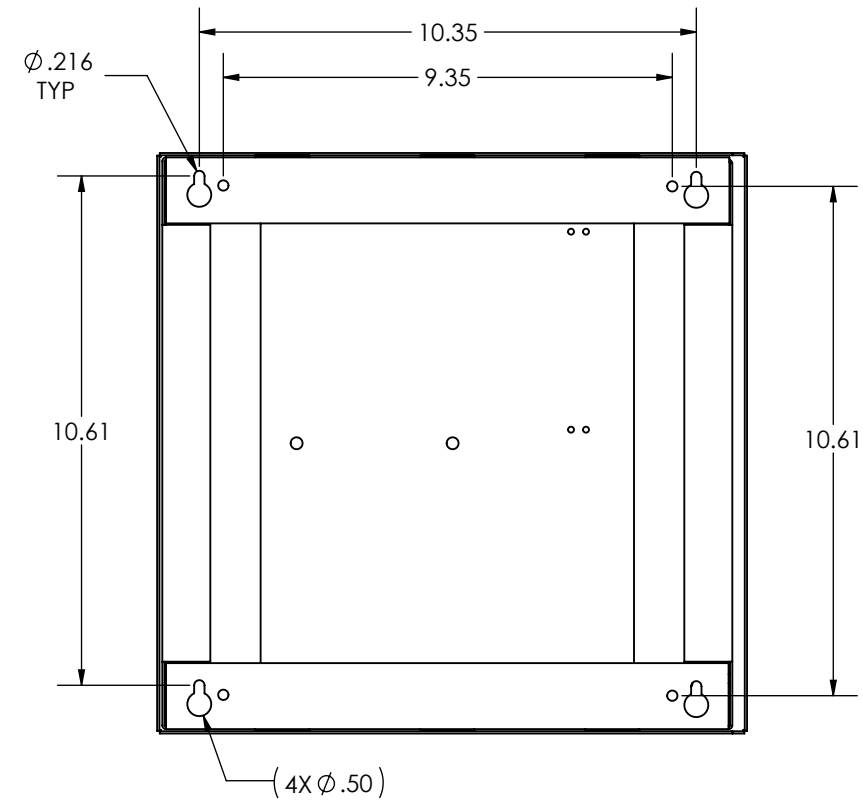
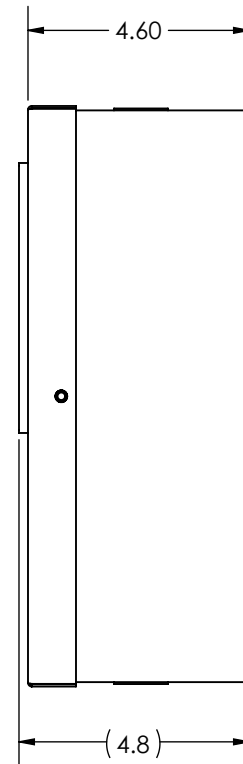
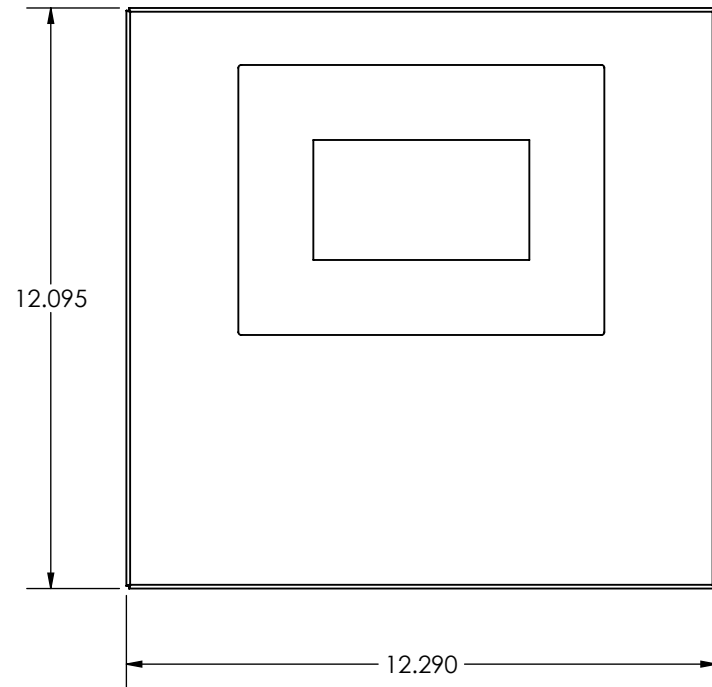

UNLESS OTHERWISE SPECIFIED
DIMENSIONS ARE IN INCHES
TOLERANCES:
FRACTIONAL ± 1/8
ANGULAR: ± 0.5° BEND ± 2°
DECIMAL
XXX = ± .010
XX = ± .020
X = ± .030
HOLE DIA. +.003/- .000

THIRD ANGLE PROJECTION

BY	MG	DATE	2017-02-24
CHECKED	-	DATE	2017-02-24
CNC PROGRAM	---		
FINISH:	X	MATERIAL	N/A
THICKNESS	N/A	SCALE	1:4

FINAL ASSEMBLY REMOTE SUPERVISORY PANEL ADV. M52 CONTROLLER	
PART NAME REMOTE SUPERVISORY PANEL	
SIZE B	DWG. NO. REMOTE-SUP-PANEL
REV. SEE TABLE	SHEET 1 OF 1

CONFIDENTIAL: THE COPYRIGHT OF THIS DOCUMENT IS RESERVED BY CLIMATEWORX. THIS DOCUMENT IS ISSUED ON THE CONDITION THAT IT IS NOT COPIED, REPRODUCED OR DISCLOSED TO ANY OTHER PARTY WITHOUT WRITTEN CONSENT OF CLIMATEWORX.