

DATE PRINTED: 3/27/2013

| REVISIONS |             |      |          |
|-----------|-------------|------|----------|
| REV.      | DESCRIPTION | DATE | APPROVED |
| -         | -           | -    | -        |
| -         | -           | -    | -        |

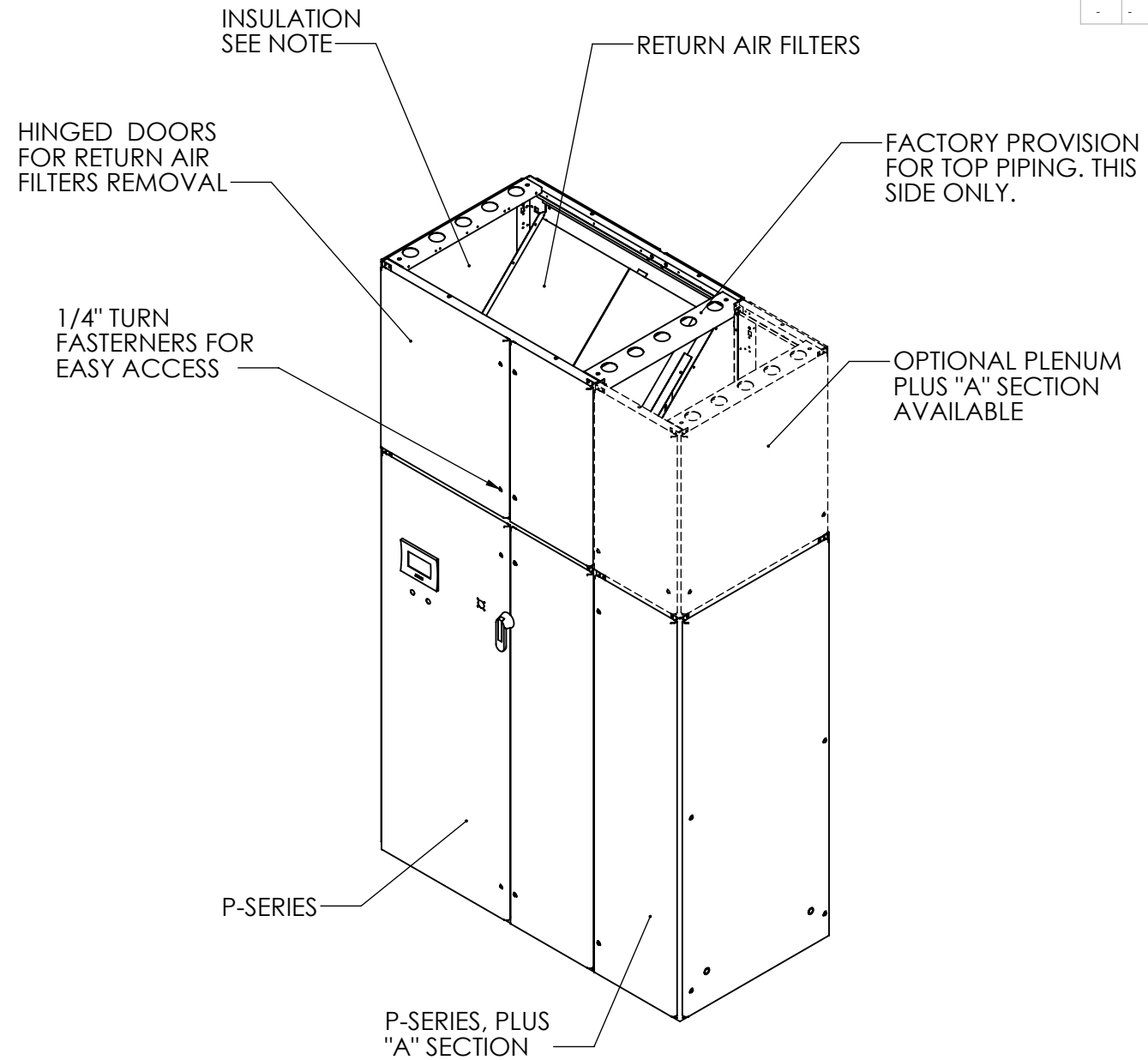
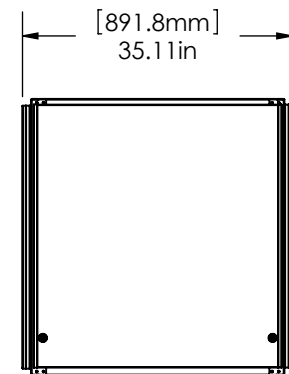
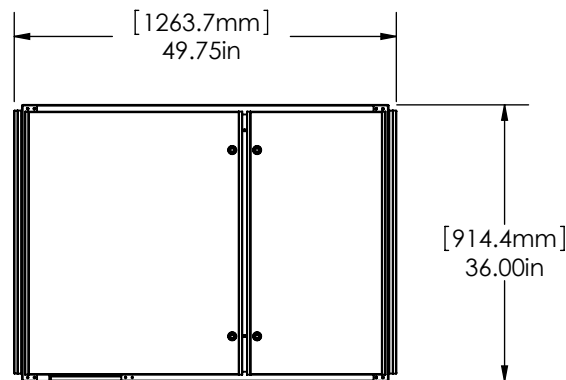
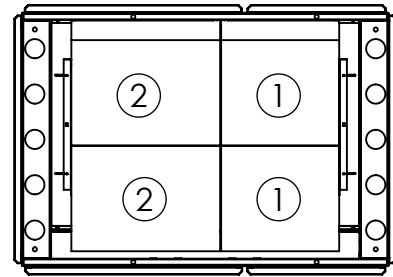

NOTES:

TABEL OF FILTERS USED

| ITEM | FILTER SIZE | QTY |
|------|-------------|-----|
| 1    | 16X20X4     | 2   |
| 2    | 20X20X4     | 2   |
| 3    | 20X24X4     | -   |
| 4    | 20X25X4     | -   |

NOTE: OTHER FILTER ARRANGEMENTS ARE AVAILABLE UPON REQUEST.

NOTE:

- 1/4" -UNIFOAM S82N UL-94 HF-1. (OPTIONAL).
- FIBRE INSULATION. NFPA-90A. A MIN 1" THICK, 24 kg/m3 (1 1/2 lb/ft3) DENSITY FIBRE INSULATION.

UNLESS OTHERWISE SPECIFIED  
DIMENSIONS ARE IN INCHES  
TOLERANCES:  
FRACTIONAL ± 1/8  
ANGULAR: ± 0.5° BEND ±2°  
DECIMAL  
XXX = ±.010  
XX = ±.020  
X = ±.030  
HOLE DIA. +.003/-0.000

THIRD ANGLE PROJECTION



|             | BY                  | DATE          |
|-------------|---------------------|---------------|
| DRAWN       | IZ                  | 11/06/2009    |
| CHECKED     | GN                  | 11/06/2009    |
| CNC PROGRAM |                     |               |
|             |                     |               |
|             |                     |               |
| FINISH:     | TEXTURED POWDERCOAT |               |
| MATERIAL    | N/A                 | THICKNESS N/A |



|                |          |                           |                          |
|----------------|----------|---------------------------|--------------------------|
| FINAL ASSEMBLY |          | DOWNFLOW DISCHARGE PLENUM |                          |
|                |          | SPDP-DP                   |                          |
| PART NAME      |          | SPDP-DP                   |                          |
| SIZE           | DWG. NO. |                           |                          |
| <b>B</b>       | SPDP-DP  | REV. SEE TABLE            |                          |
| BD             | N/A      | K                         | SCALE: 1:20 SHEET 1 OF 1 |

**CONFIDENTIAL:** THE COPYRIGHT OF THIS DOCUMENT IS RESERVED BY CLIMATEWORX. THIS DOCUMENT IS ISSUED ON THE CONDITION THAT IT IS NOT COPIED, REPRODUCED OR DISCLOSED TO ANY OTHER PARTY WITHOUT WRITTEN CONSENT OF CLIMATEWORX.